



www.MIPonline.com

# MIP X-Duty™ Instruction Guide



8-32  
Setscrew (x4)  
#00-209



M4 Locknut  
(x2)  
#00-184

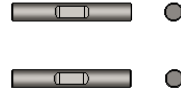

Cross Pin (x4)  
#18100



2mm  
Spacer (x4)  
#20050

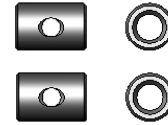

Coupling (x4)  
#18100



M4 x 12mm  
Pin Screw (x2)  
#99120



1mm  
Spacer (x2)  
#20050



M3 Setscrew  
(x2)  
#12140

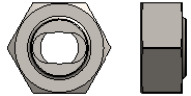

12mm Hex  
Adapter (x2)  
#12140

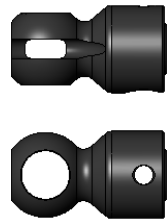

Drive Hub,  
16mm (x2)  
#18112

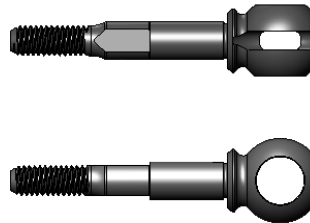

Rear Axle, 5mm  
Bearing (x2)  
#18141

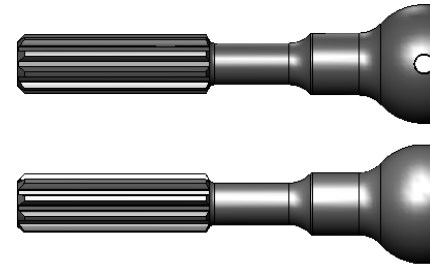

X-Duty Male,  
54mm (x2)  
#18103

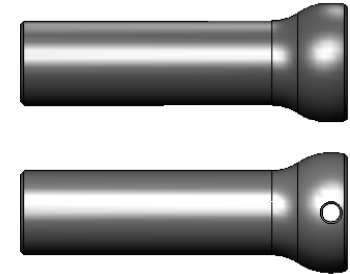

X-Duty Female,  
40mm (x2)  
#18101



Apply MIP  
Thread Lock



**WARNING!!!**  
Chemicals in tubes  
may cause eye/skin  
irritation and can be  
harmful if  
swallowed. If it  
comes in contact  
with skin, wash with  
plenty of soap and  
water. If in eyes;  
Rinse with water for  
fifteen minutes. If  
irritation persists get  
medical advice.

For more information  
& SDS please visit:  
[www.miponline.com/store/sds.html](http://www.miponline.com/store/sds.html)



Apply MIP Lube

© 2020  
Moore's Ideal Products, LLC  
830 W. Golden Grove Way  
Covina, CA 91722



www.MIPonline.com

# MIP X-Duty™ Instruction Guide

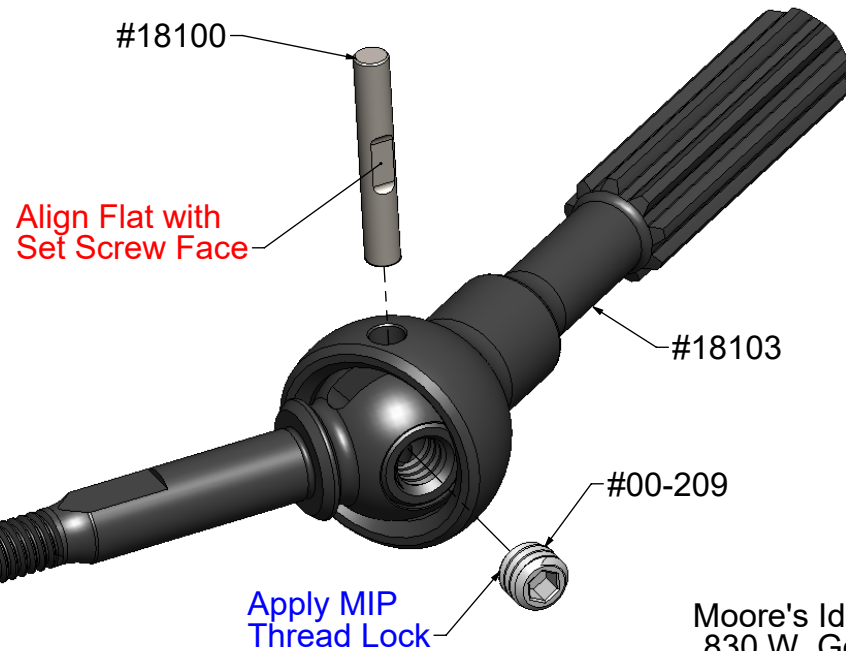
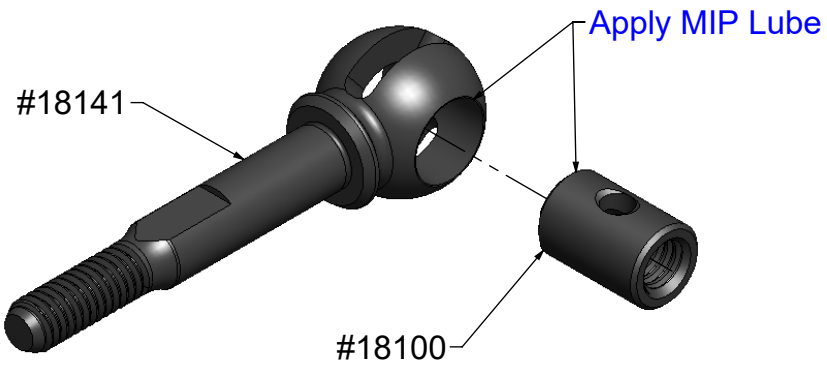
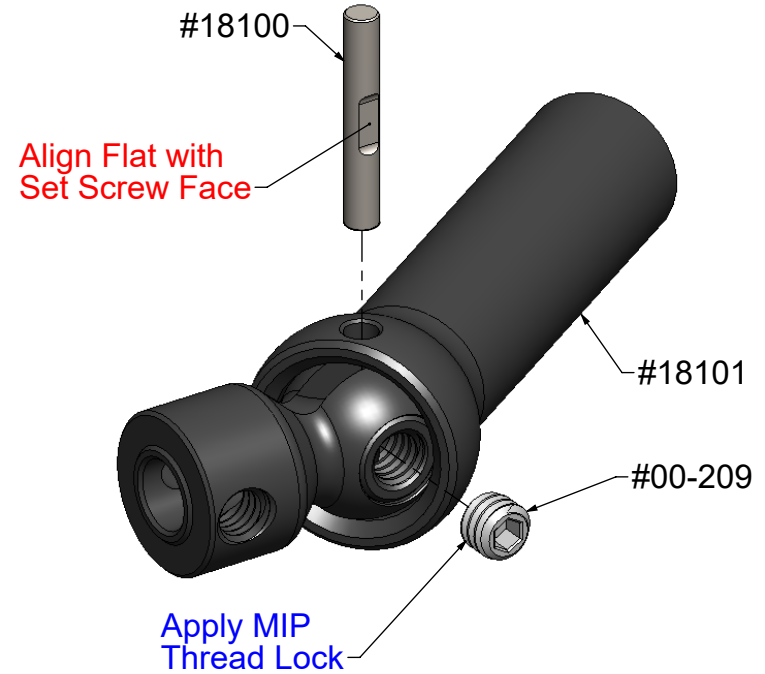
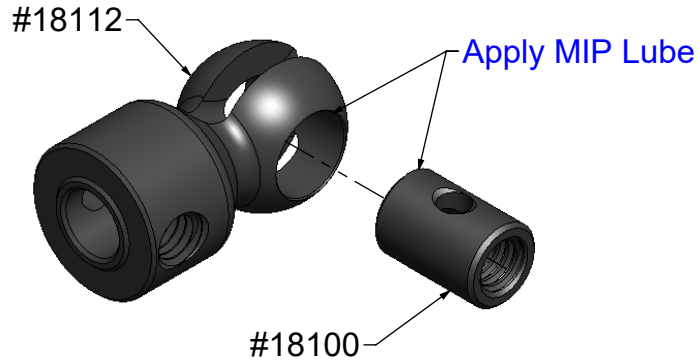

P/N: 18140

© 2020  
 Moore's Ideal Products, LLC  
 830 W. Golden Grove Way  
 Covina, CA 91722



www.MIPonline.com

# MIP X-Duty™ Instruction Guide

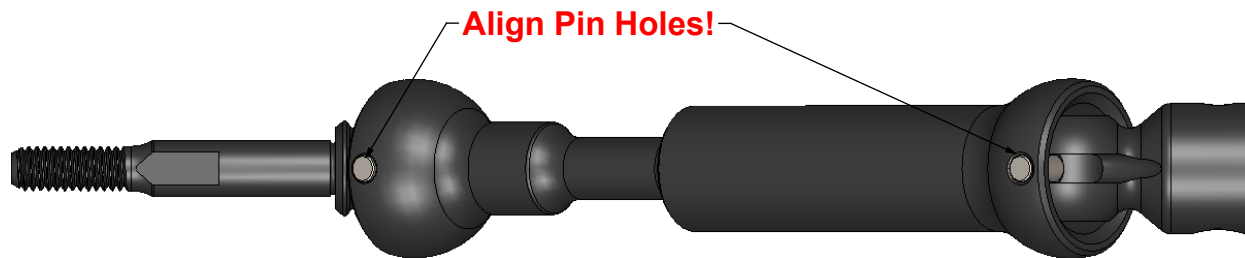
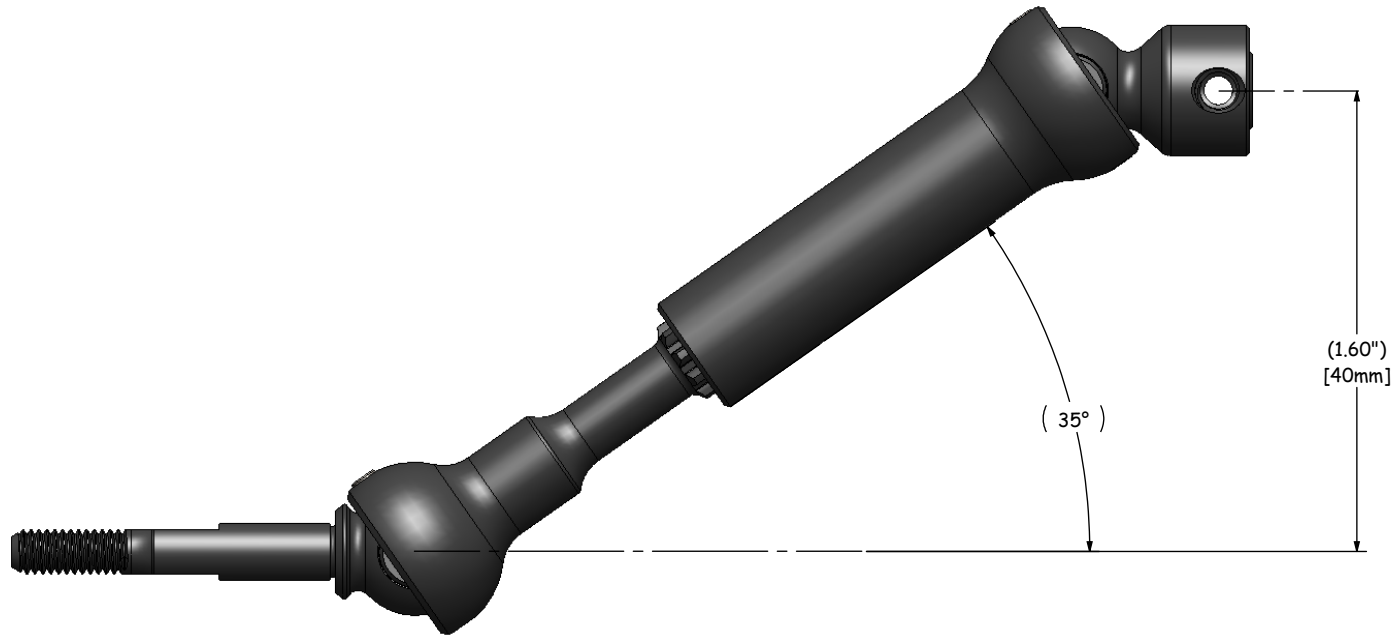



www.MIPonline.com

# MIP X-Duty™ Instruction Guide

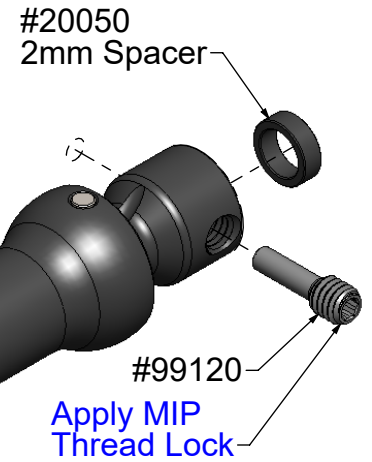

NOT INCLUDED!

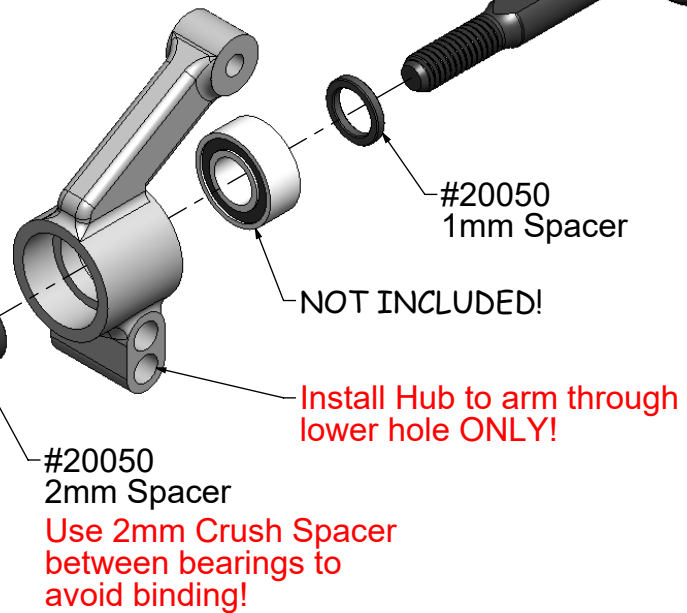
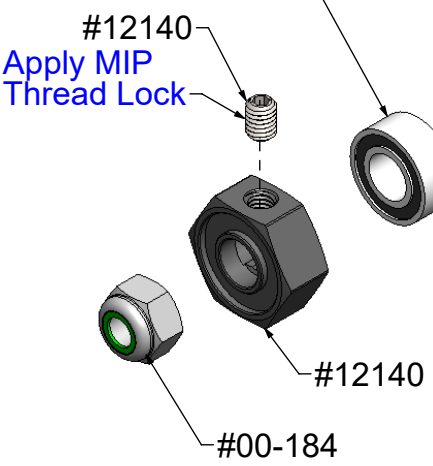

Install Hub to arm through lower hole ONLY!

## Drive Installation

© 2020  
Moore's Ideal Products, LLC  
830 W. Golden Grove Way  
Covina, CA 91722