

HORIZON[®]
H O B B Y

E-flite[®]
ADVANCING ELECTRIC FLIGHT

Air Tractor

1.5m

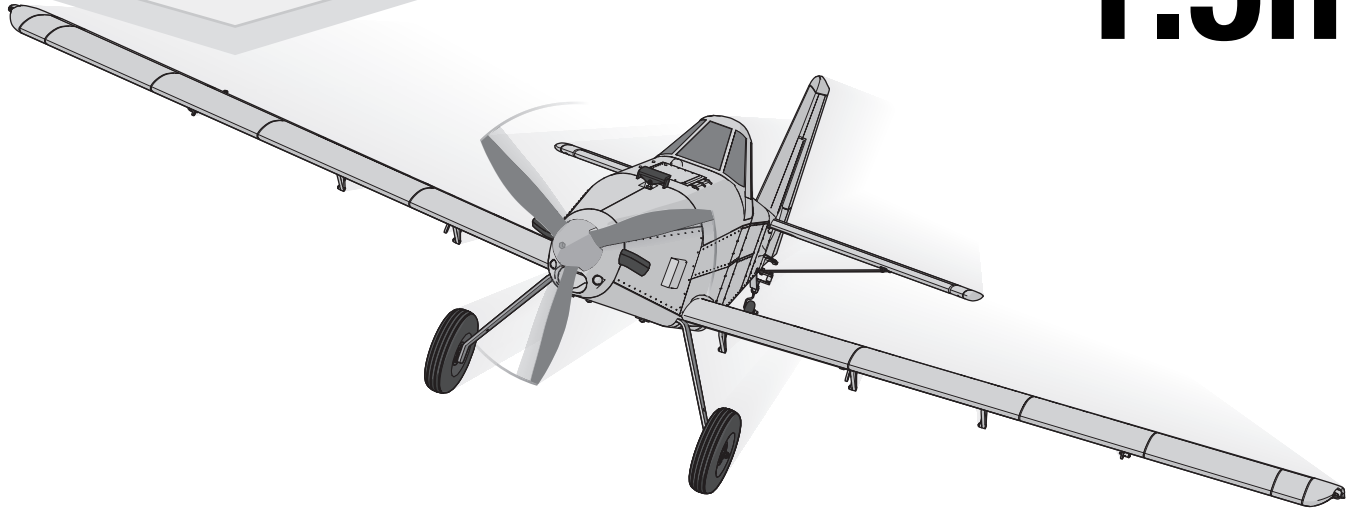

*Instruction Manual
Bedienungsanleitung
Manuel d'utilisation
Manuale di Istruzioni*

SAFE[®] 

SAFE[®] Select Technology, Optional Flight Envelope Protection

Bind-N-Fly[®] **Plug-N-Play**[®]
BASIC

NOTICE

All instructions, warranties and other collateral documents are subject to change at the sole discretion of Horizon Hobby, LLC. For up-to-date product literature, visit www.horizonhobby.com or www.towerhobbies.com and click on the support or resources tab for this product.

Meaning of Special Language:

The following terms are used throughout the product literature to indicate various levels of potential harm when operating this product:

WARNING: Procedures, which if not properly followed, create the probability of property damage, collateral damage, and serious injury OR create a high probability of superficial injury.

CAUTION: Procedures, which if not properly followed, create the probability of physical property damage AND a possibility of serious injury.

NOTICE: Procedures, which if not properly followed, create a possibility of physical property damage AND little or no possibility of injury.



WARNING: Read the ENTIRE instruction manual to become familiar with the features of the product before operating. Failure to operate the product correctly can result in damage to the product, personal property and cause serious injury.

This is a sophisticated hobby product. It must be operated with caution and common sense and requires some basic mechanical ability. Failure to operate this Product in a safe and responsible manner could result in injury or damage to the product or other property. This product is not intended for use by children without direct adult supervision. Do not use with incompatible components or alter this product in any way outside of the instructions provided by Horizon Hobby, LLC. This manual contains instructions for safety, operation and maintenance. It is essential to read and follow all the instructions and warnings in the manual, prior to assembly, setup or use, in order to operate correctly and avoid damage or serious injury.

14+

AGE RECOMMENDATION:
Not for children under 14 years. This is not a toy.



WARNING AGAINST COUNTERFEIT PRODUCTS: If you ever need to replace your Spektrum receiver found in a Horizon Hobby product, always purchase from Horizon Hobby, LLC or a Horizon Hobby authorized dealer to ensure authentic high-quality Spektrum product. Horizon Hobby, LLC disclaims all support and warranty with regards, but not limited to, compatibility and performance of counterfeit products or products claiming compatibility with DSM or Spektrum technology.

Safety Precautions and Warnings







As the user of this product, you are solely responsible for operating in a manner that does not endanger yourself and others or result in damage to the product or the property of others.

- Always keep a safe distance in all directions around your model to avoid collisions or injury. This model is controlled by a radio signal subject to interference from many sources outside your control. Interference can cause momentary loss of control.
- Always operate your model in open spaces away from full-size vehicles, traffic and people.
- Always carefully follow the directions and warnings for this and any optional support equipment (chargers, rechargeable battery packs, etc.).
- Always keep all chemicals, small parts and anything electrical out of the reach of children.
- Always avoid water exposure to all equipment not specifically designed and protected for this purpose. Moisture causes damage to electronics.
- Never place any portion of the model in your mouth as it could cause serious injury or even death.
- Never operate your model with low transmitter batteries.
- Always keep aircraft in sight and under control.
- Always use fully charged batteries.
- Always keep transmitter powered on while aircraft is powered.
- Always remove batteries before disassembly.
- Always keep moving parts clean.
- Always keep parts dry.
- Always let parts cool after use before touching.
- Always remove batteries after use.
- Always ensure failsafe is properly set before flying.
- Never operate aircraft with damaged wiring.
- Never touch moving parts.

Quick Start Information

Transmitter Setup	Set up your transmitter using the transmitter setup chart		
Dual Rates		Hi Rate	Low Rate
	Ail	▲20mm ▼20mm	▲14mm ▼14mm
	Ele	▲10mm ▼10mm	▲7mm ▼7mm
	Rud	▲32mm ▼32mm	▲22mm ▼22mm
	Flaps	Full ▼=20mm	Half ▼=10mm
Center of Gravity (CG)	65mm +/-5mm back from leading edge of wing at the fuselage		
Flight Timer Setting	4 minutes		

Specifications

		BNF BASIC	PNP PLUG-N-PLAY
	Motor: BL10 800Kv Brushless outrunner (EFLM17552)	Installed	Installed
	ESCs: 50AMP Brushless ESC (EFLA1050)	Installed	Installed
	Servos: 13 gram metal geared servos (5x SPMSA332) (1xSPMSA330R)	Installed	Installed
	Receiver: Spektrum™ AR637TA 6-Channel Sport Receiver (SPMAR637TA)	Installed	Required to Complete
	Recommended Battery: 11.1V(3S)–14.8V(4S) 2200–3200mAh 30C Li-Po (SPMX22003S30–SPMX32004S100) with EC3 or IC3 connector	Required to Complete	Required to Complete
	Recommended Battery Charger: 3–4 cell Li-Po battery balancing charger	Required to Complete	Required to Complete
	Recommended Transmitter: Full-Range 6 channel 2.4GHz with Spektrum DSMX® technology with adjustable Dual Rates.	Required to Complete	Required to Complete

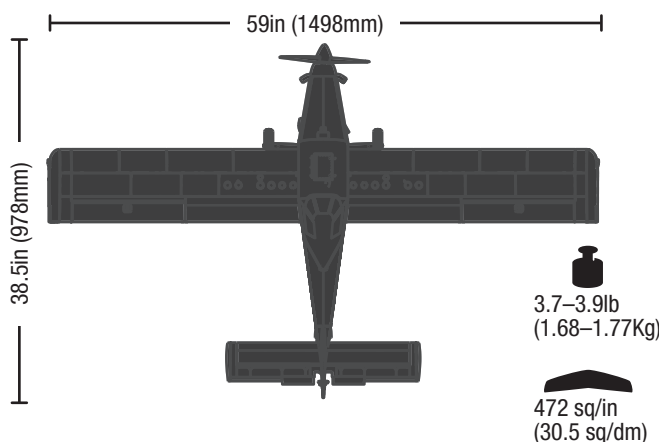

As of this printing, you may be required to register with the FAA if you own this product.

For up-to-date information on how to register with the FAA, please visit <https://registermyuas.faa.gov/>. For additional assistance on regulations and guidance on UAS usage, visit knowbeforeyoufly.org/.

Box Contents

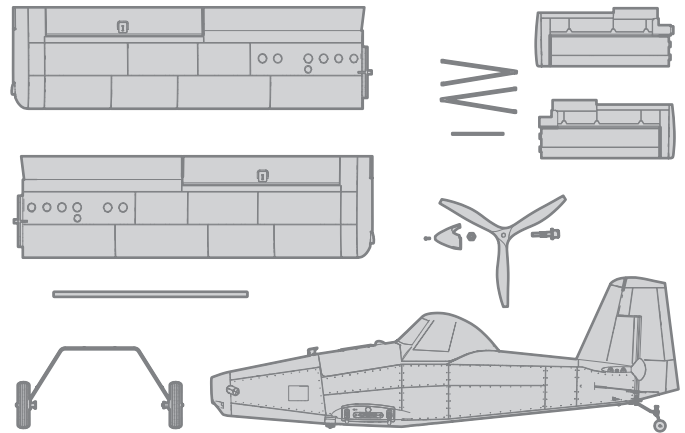

Table of Contents

SAFE® Select Technology (BNF Basic)	4
Preflight.....	4
Model Assembly	4
Model Assembly Continued	5
Receiver Installation (PNP)	7
Transmitter Setup (BNF)	7
Battery Installation and ESC Arming	8
Center of Gravity	8
Binding	9
SAFE Select Switch Designation.....	10
Control Surface Direction	11
Control Horn and Servo Arm Settings	11
AS3X Control Direction Test (BNF)	12
In Flight Trimming (BNF).....	12
Flying Tips and Repairs	13
SAFE Select Flying Tips.....	13
Post Flight	14
Motor Service	14
Troubleshooting Guide AS3X	15
Troubleshooting Guide	15
Float Installation (Optional).....	16
Flying Off Water	16
Ski Installation (Optional)	17
Replacement Parts.....	18
Optional Parts	18
Recommended Receivers (PNP)	18
AMA National Model Aircraft Safety Code	19
Limited Warranty	20
Contact Information	20
FCC Information.....	21
IC Information.....	21
Compliance Information for the European Union.....	21

To receive product updates, special offers and more, register your product at <https://www.horizonhobby.com/content/e-flite-rc>

SAFE® Select Technology (BNF Basic)

The BNF Basic version of this airplane includes SAFE Select technology which can offer an extra level of protection in flight. Use the following instructions to make the SAFE Select system active and assign it to a switch. When enabled, SAFE Select prevents the airplane from banking or pitching past predetermined limits, and automatic self-leveling keeps the airplane flying in a straight and level attitude when the aileron, elevator and rudder sticks are at neutral.

SAFE Select is enabled or disabled during the bind process. When the airplane is bound with SAFE Select enabled, a switch can be assigned to toggle between SAFE Select mode and AS3X mode. AS3X® technology remains active with no banking limits or self leveling any time SAFE Select is disabled or OFF.

SAFE Select can be configured three ways;

- SAFE Select Off: Always in AS3X mode
- SAFE Select On with no switch assigned: Always in SAFE Select mode
- SAFE Select On with a switch assigned: Switch toggles between SAFE Select mode and AS3X mode

Preflight

1. Remove and inspect contents.
2. Read this instruction manual thoroughly.
3. Charge the flight battery.
4. Setup Transmitter using transmitter setup chart.
5. Fully assemble the airplane.
6. Install the flight battery in the aircraft (once it has been fully charged).
7. Check the Center of Gravity (CG).
8. Bind the aircraft to your transmitter.

9. Make sure linkages move freely.
10. Test the flap operation.
11. Perform the Control Direction Test with the transmitter.
12. Perform the AS3X Control Direction Test with the aircraft.
13. Adjust flight controls and transmitter.
14. Perform a radio system Range Test.
15. Find a safe open area to fly.
16. Plan flight for flying field conditions.

Model Assembly

Landing Gear Installation

1. Install the landing gear with the two included 3mm x 8mm screws.

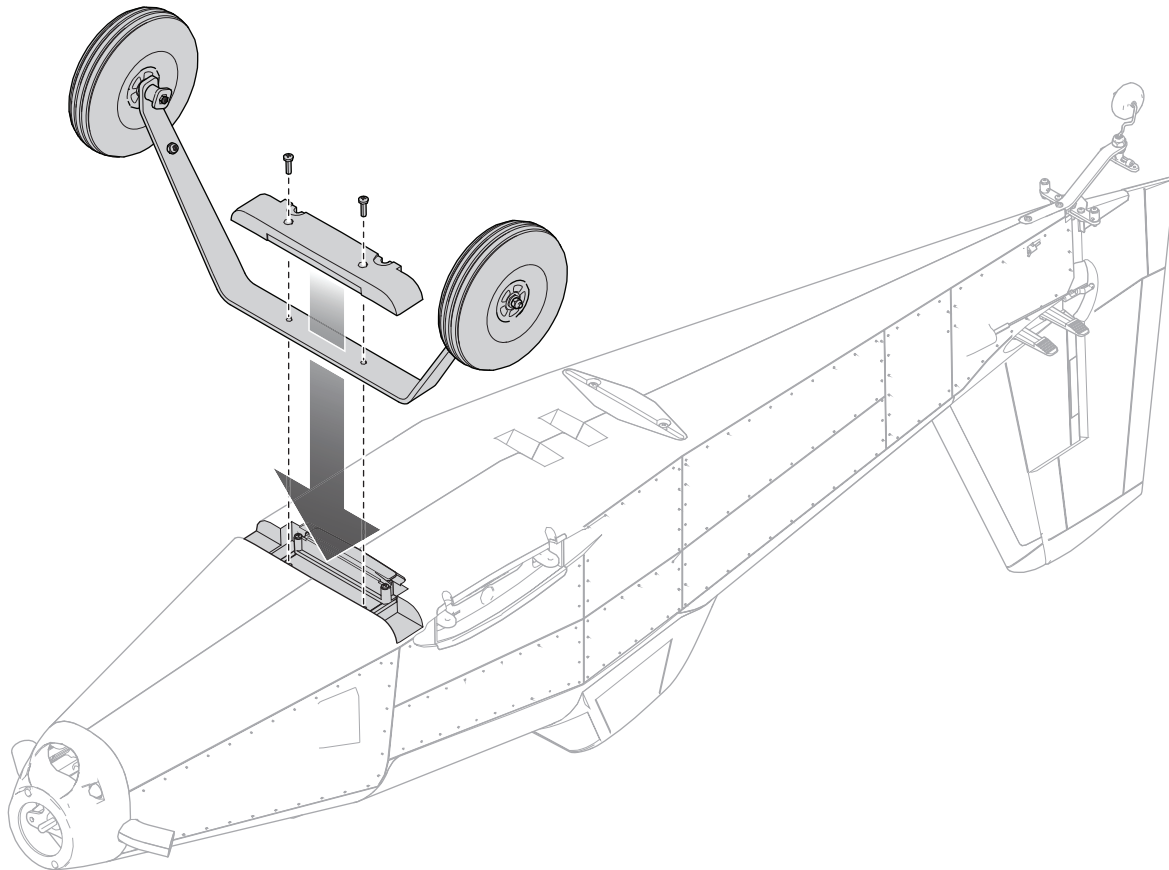

Model Assembly *Continued*

Horizontal Stabilizer Installation

1. Slide the tail joiner tube into the fuselage.
2. Slide the horizontal tail halves onto the joiner tube.
3. The retainers will click when the tail parts lock into position.

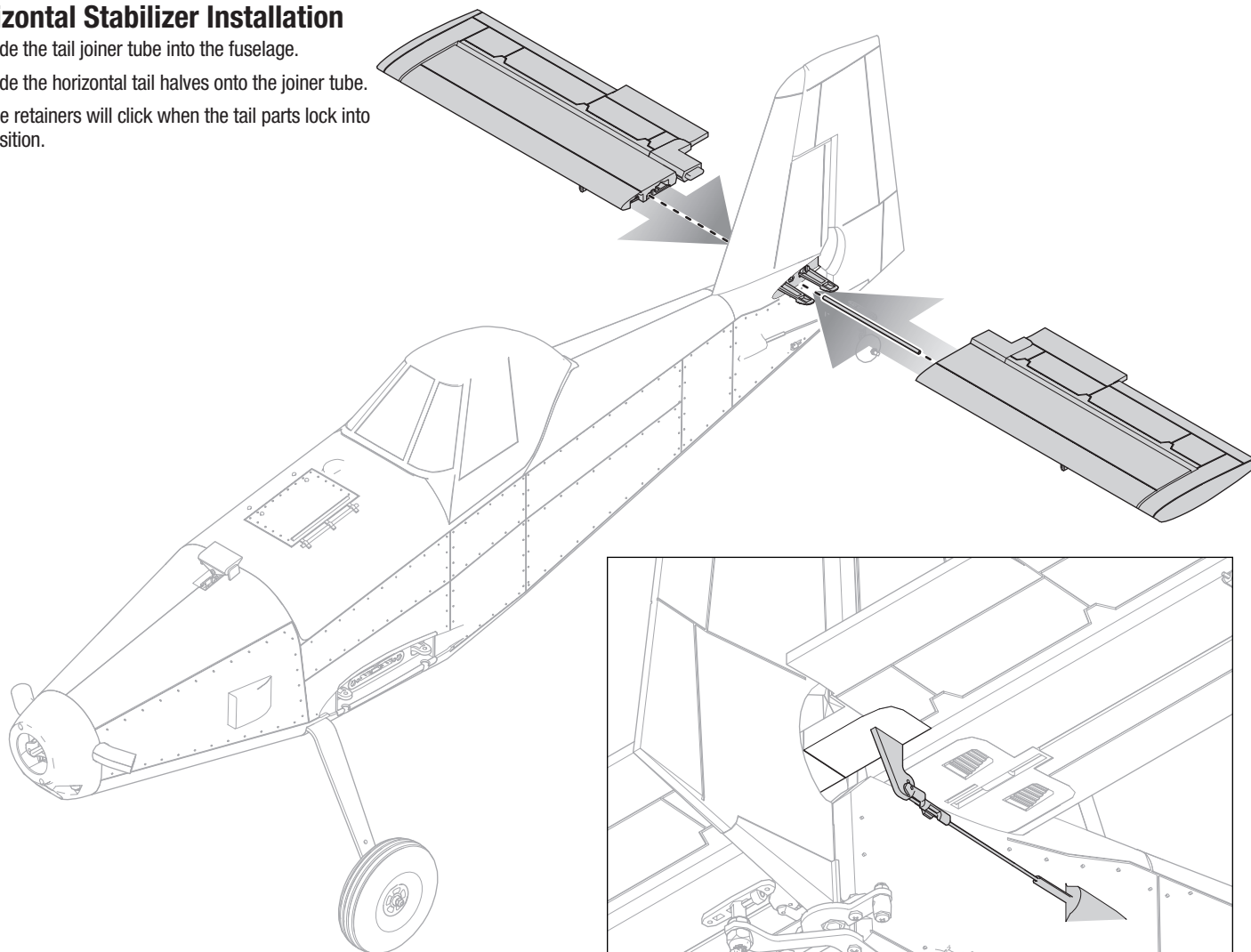

4. Insert the elevator pushrod into the outside hole on the elevator control horn.
5. Slide the pushrod keeper onto the end of the pushrod.
6. Rotate the pushrod keeper onto the pushrod and snap it into position on the pushrod.

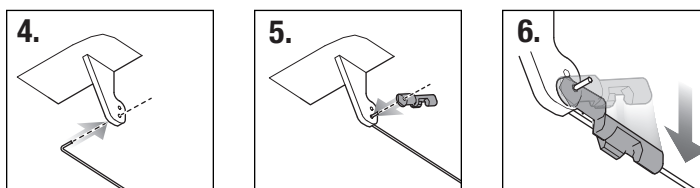
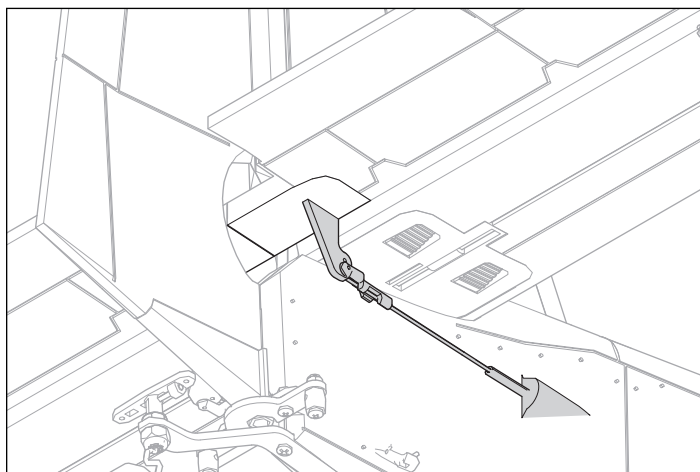

7. Locate the horizontal stabilizer brace mounting points on the bottom of the horizontal stabilizer and the sides of the fuselage.
8. Secure the braces in position with the six 2mm x 8mm self-tapping screws.

Disassemble in reverse order.

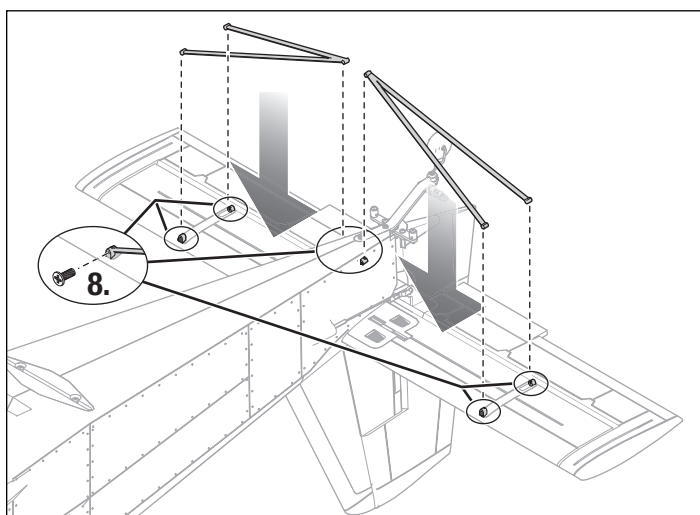

Wing Installation

1. Slide the wing tube into the fuselage.
2. Slide the wings onto the wing tube.
3. Secure the wing halves into position from the bottom using the four included 3mm x 8mm machine screws.

Disassemble in reverse order.

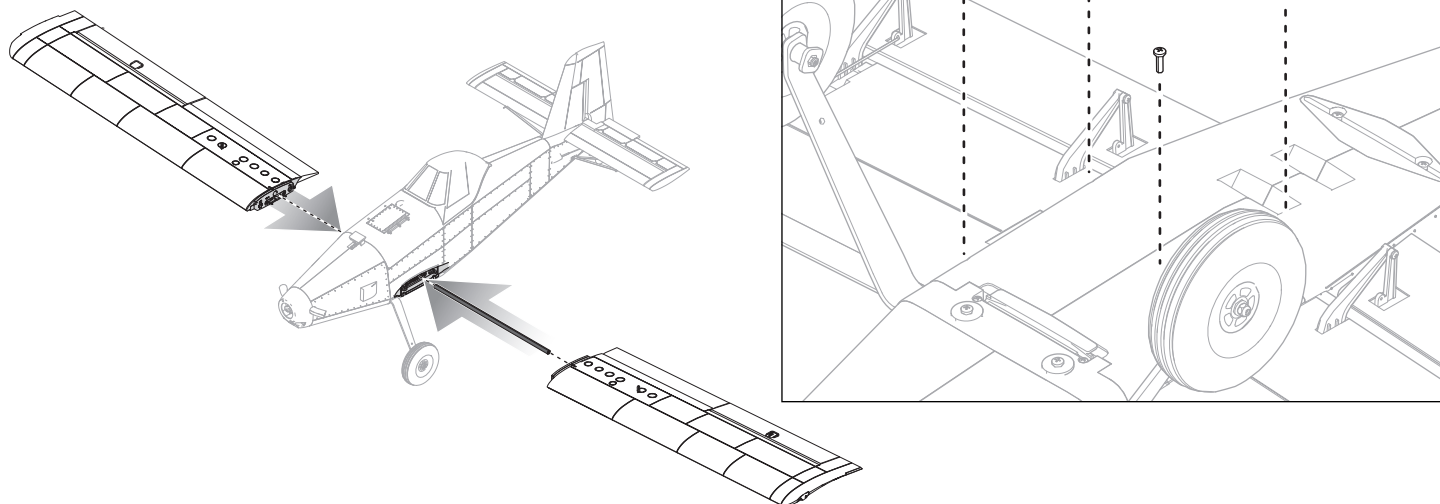

Propeller Installation

1. Install the Prop adapter, propeller, prop washer and nut.
2. Tighten the nut until the prop adaptor grasps the propeller shaft securely.
3. Secure the spinner with a 3 x 8mm screw.

Disassemble in reverse order.



WARNING: Do not install the propeller until all system setups are complete. Failure to heed this warning could result in severe personal injury.

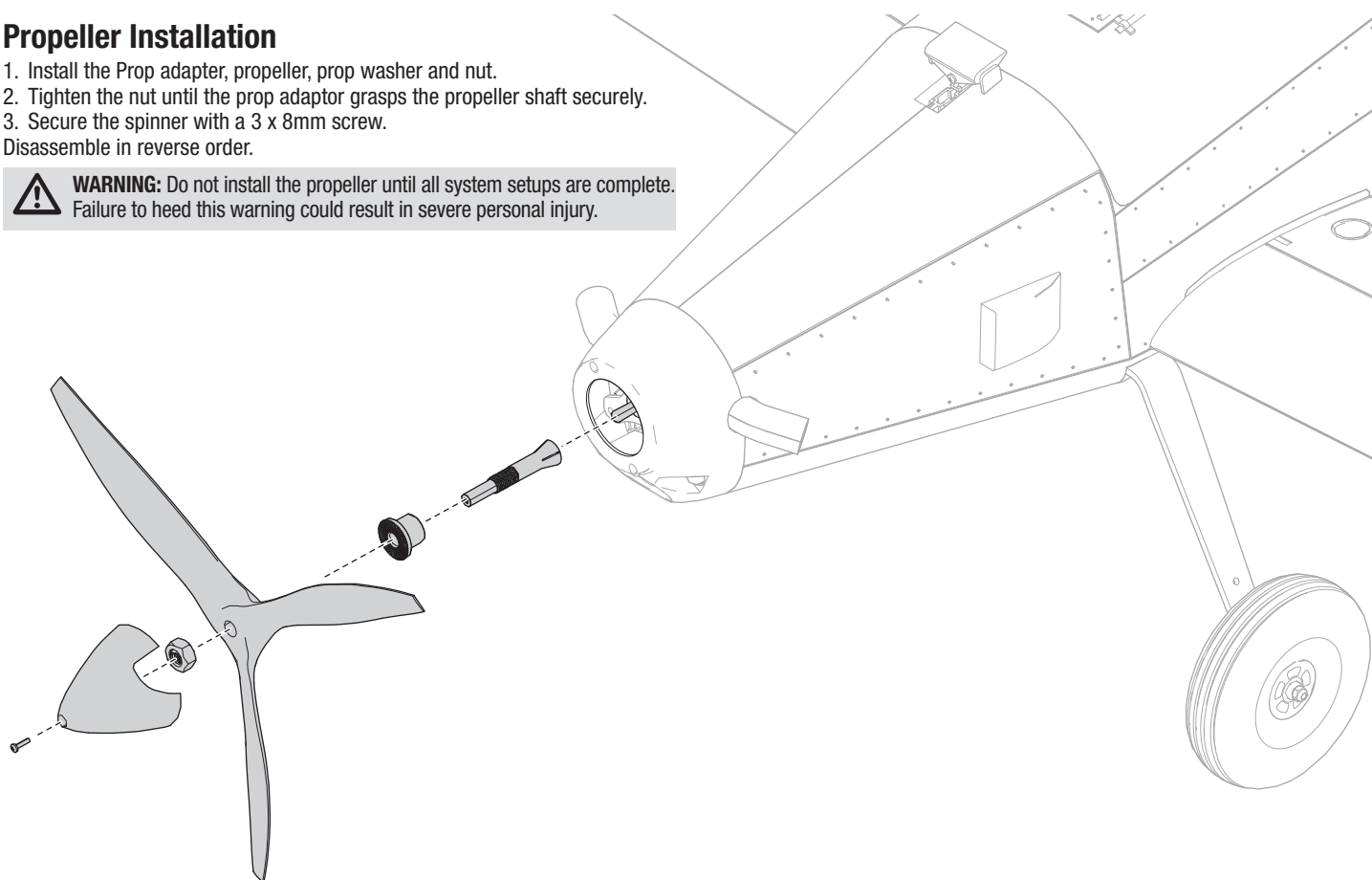

Receiver Installation (PNP)

The recommended receiver for this aircraft is the Spektrum AR637T. If you choose to install a different receiver, ensure that it is at least a 6-channel full range receiver. Refer to the manual of your chosen receiver for correct installation and operation instructions.

AR637T Installation

1. Slide the canopy latch (A) back and lift the back of the canopy to remove the canopy from the fuselage.
2. Attach the appropriate control surfaces to their respective ports on the receiver using the table at the right.
3. Using double-sided servo tape, (not included) mount the receiver to the flat area behind the battery compartment, as shown. The receiver should be mounted in the orientation shown, parallel to the length of the fuselage, with the label facing up and the servo ports facing the front of the aircraft. The orientation of the receiver is critical for all AS3X® and SAFE® technology setups.



CAUTION: Incorrect installation of the receiver could cause a crash.

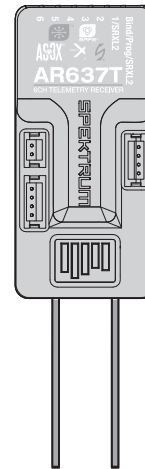

AR637T Port Assignments

BND/PRG = BIND

- | | |
|--------------|------------|
| 1 = Throttle | 4 = Rudder |
| 2 = Ailerons | 5 = Lights |
| 3 = Elevator | 6 = Flaps |

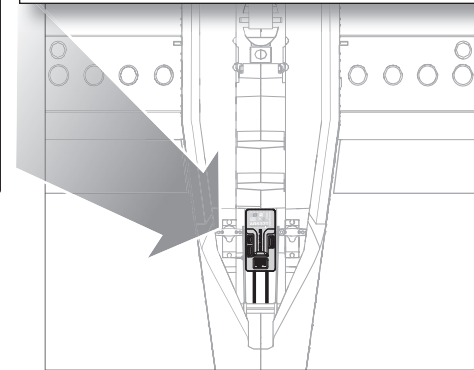

Transmitter Setup (BNF)

IMPORTANT: After you set up your model, always rebind the transmitter and receiver to set the desired failsafe positions with the throttle stick and trim in the lowest position.

The FLAP Channel (CH 6) controls the flaps. SAFE select may be on a dedicated switch or combined with the flap operation. When using one switch for both functions, the switch will enable SAFE for half and full flap positions and AS3X only when the flaps are up. See the SAFE Select Switch Designation section of this manual to assign the switch for SAFE select.

TIP: If you choose to use the FLAP Channel (CH 6) to operate both the flap and SAFE select, there is an extra step required during setup. The values need to be temporarily set to +100 and -100 and the speed set to 0 in the flap system menu. Complete the SAFE Select switch assignment process with these settings, and then change the flap system values back to the values listed in the setup table.

Dual Rates

Attempt your first flights in Low Rate. For landings, use high rate elevator.

NOTICE: To ensure AS3X technology functions properly, do not lower rate values below 50%. If less control deflection is desired, manually adjust the position of the pushrods on the servo arm

NOTICE: If oscillation occurs at high speed, refer to the Troubleshooting Guide for more information.

Expo

After first flights, you may adjust expo in your transmitter.

Computerized Transmitter Setup

Start all transmitter programming with a blank ACRO model (perform a model reset), then name the model.		
Set Dual Rates to	HIGH 100%	LOW 70%
Set Servo Travel to	100%	
Set Throttle Cut to	-100%	
Set Aileron Expo to	High Rate 15%	Low Rate 5%
Set Elevator Expo to	High Rate 10%	Low Rate 5%
Set Rudder Expo to	High Rate 10%	Low Rate 5%
DXe	Refer to spektrumrc.com for the appropriate download setup.	
DX6i	1. Go to the SETUP LIST MENU	
	2. Set MODEL TYPE: ACRO	
	3. Go to ADJUST LIST MENU	
	4. Set TRAVEL: FLAPS ↑100 ↓-100	
	5. Set FLAPS: Norm ↓ 0 Flap Elev 0 LAND ↑-100 Flap Elev 10	
DX7S DX8	1. Go to the SYSTEM SETUP	
	2. Set MODEL TYPE: AIRPLANE	
	3. Set WING TYPE: 1 AIL 1 FLAP	
	4. Go to the FUNCTION LIST	
	5. Set TRAVEL: FLAPS ↑100 ↓-100	
	6. Set FLAP SYSTEM: Choose Flap NORM: -100% FLAP MID: 0% FLAP 6% Elevator LAND: 100% FLAP 10% Elevator SPEED 2.0S: SWITCH = FLAP	
DX6e	1. Go to the SYSTEM SETUP (Model Utilities)†	
DX6 (Gen2)	2. Set MODEL TYPE: AIRPLANE	
DX7 (Gen2)	3. Set AIRCRAFT TYPE (Model Setup, Aircraft Type)†: WING: 1 AIL 1 FLAP	
DX8e	4. Set CHANNEL ASSIGN (Model Setup, Channel Assign)†: (Default switch assignments with a new model setup) Flap (CH6): SWITCH D	
DX8 (Gen2)	4. Set CHANNEL ASSIGN (Model Setup, Channel Assign)†: (Default switch assignments with a new model setup) Flap (CH6): SWITCH D	
DX9	5. Go to the FUNCTION LIST (Model Adjust)†	
DX10t	6. Set FLAP SYSTEM:	
DX18	SELECT SWITCH D:	
DX20	POS 0: 100% FLAP*	
iX12	POS 1: 0% FLAP* 6% Elevator	
iX20	POS 2: -100% FLAP* 10% Elevator	
	SPEED 2.0	

† Some of the terminology and function locations used in the iX12 and iX20 programming may be slightly different than other Spektrum AirWare™ radios. The names given in parenthesis correspond to the iX12 and iX20 programming terminology. Consult your transmitter manual for specific information about programming your transmitter.

* Flap programming values may vary slightly. For your initial flights use the recommended flap travel settings provided in the Flaps section and adjust the flap travel to your preference on subsequent flights.

Battery Installation and ESC Arming

Battery Selection

A 3S or 4S 2200–3200mAh LiPo battery is required. The Spektrum 3200mAh 14.8V 4S 50C LiPo battery (SPMX32004S50) is recommended. Refer to the Optional Parts List for other recommended batteries. If using a battery other than those listed, the battery should be within the range of capacity, dimensions and weight of the Spektrum Li-Po battery packs to fit in the fuselage. Be sure the model balances at the recommended CG before flying.

1. Lower the throttle and throttle trim to the lowest settings. Power on the transmitter, then wait 5 seconds.
2. Remove the battery hatch.
3. For added security, apply the loop side (soft side) of the optional hook and loop tape to the bottom of your battery, and the hook side to the battery tray.
4. Install the fully charged battery to the front of the battery compartment as shown below under Center of Gravity. Secure using the hook and loop straps.
5. Connect the battery to the ESC. If you have not completed the bind sequence, do so at this time as outlined in this manual.

CAUTION: Always keep hands away from the propeller. When armed, the motor will turn the prop in response to any throttle movement.

6. Keep the aircraft immobile and away from wind or the system will not initialize.
 - The motor will emit a series of rising tones when the battery is connected, and then 3 or 4 even tones indicating the number of cells connected.
 - An LED will light on the receiver when it is initialized.
7. Reinstall the battery hatch.

ESC Tones: If the ESC sounds a continuous double beep after the flight battery is connected, recharge or replace the battery.

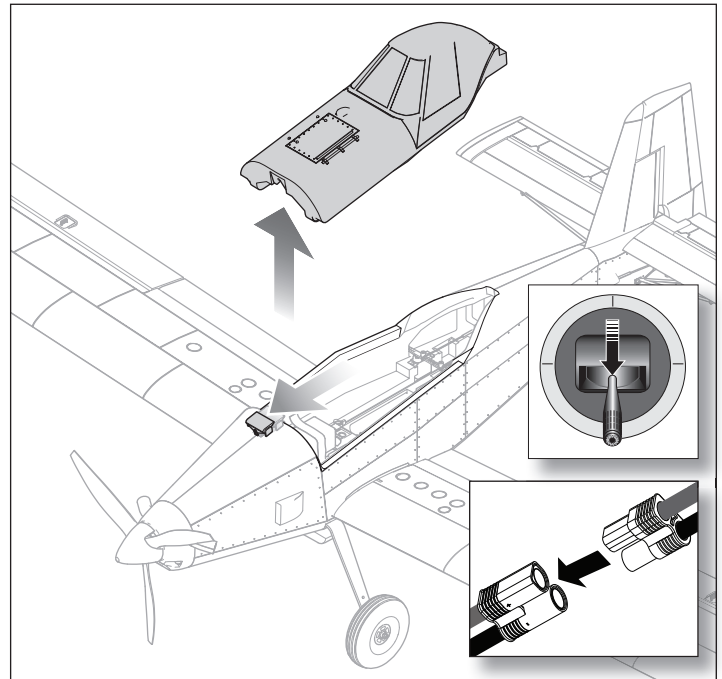

ESC Error Tones	Tone Meaning	Possible problem
Continuous slow single tones	Abnormal throttle signal	Transmitter and receiver not bound
		Throttle lead damaged or not plugged into receiver
		Throttle lead plugged into receiver backward

ESC Error Tones	Tone Meaning	Possible problem
Continuous rapid single tones	Throttle signal not at low position	Throttle stick not at low position
		Throttle travel reduced below 100%
		Throttle reversed
Continuous double tones	Battery voltage is beyond acceptable range	Verify battery is a 3 or 4-cell LiPo
		Verify battery is fully charged

Center of Gravity

The Center of Gravity (CG) location is 65mm +/- 5mm back from the leading edge of the wing. Install the recommended battery to the front of the battery compartment for the correct CG, as shown below.

CAUTION: Install the battery but do not connect it to the ESC while checking the CG. Personal injury may result.

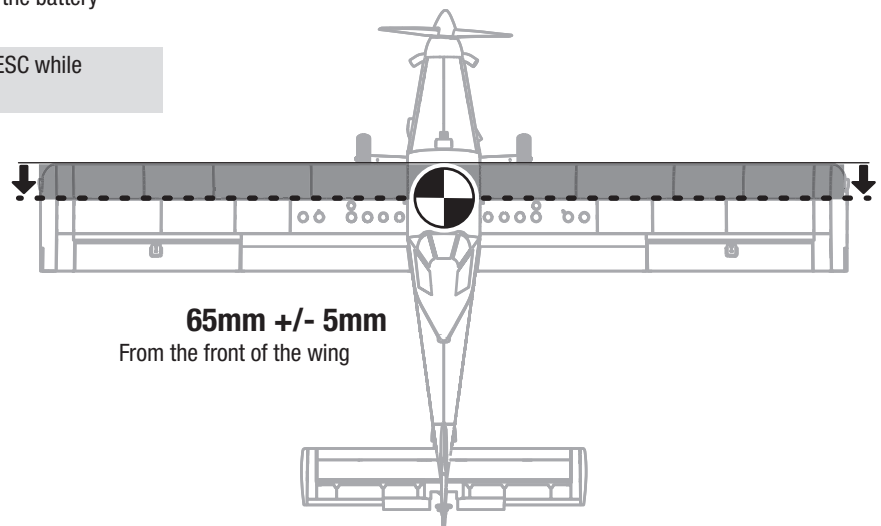
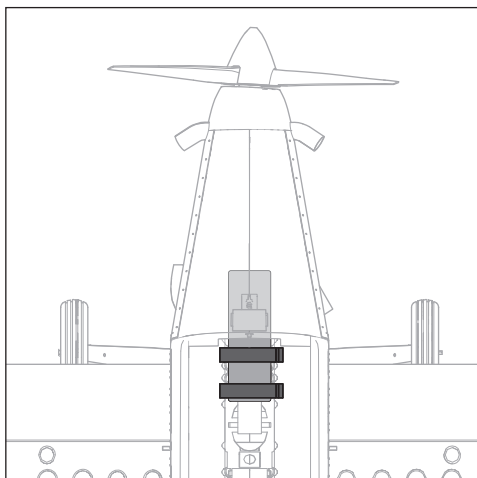

Binding

General Binding Tips

- The included receiver has been specifically programmed for operation of this aircraft. Refer to the receiver manual for correct setup if the receiver is replaced.
- Keep away from large metal objects while binding.
- Do not point the transmitter's antenna directly at the receiver while binding.
- The orange LED on the receiver will flash rapidly when the receiver enters bind mode.
- Once bound, the receiver will retain its bind settings for that transmitter until you re-bind.
- If the receiver loses transmitter communication, the failsafe will activate. Failsafe moves the throttle channel to low throttle. Pitch and roll channels move to actively level the aircraft in flight.
- If problems occur, refer to the troubleshooting guide or if needed, contact the appropriate Horizon Product Support office.

SAFE® Select Technology, Optional Flight Envelope Protection

The BNF Basic version of this airplane includes SAFE Select technology, enabling you to choose the level of flight protection. SAFE mode includes angle limits and automatic self leveling. AS3X mode provides the pilot with a direct response to the control sticks. SAFE Select is enabled or disabled during the bind process. With SAFE Select disabled the aircraft is always in AS3X mode. With SAFE Select enabled the aircraft will be in SAFE Select mode all the time, or you can assign a switch to toggle between SAFE Select and AS3X modes.

Thanks to SAFE Select technology, this aircraft can be configured for full-time SAFE mode, full-time AS3X mode, or mode selection can be assigned to a switch.

IMPORTANT: Before binding, read the transmitter setup section in this manual and complete the transmitter setup table to ensure your transmitter is properly programmed for this aircraft.

IMPORTANT: Move the transmitter flight controls (rudder, elevators, and ailerons) and the throttle trim to neutral. Move the throttle to low before and during binding. This process defines the failsafe settings.

You can use either the bind button on the receiver case or the conventional bind plug to complete the binding and SAFE Select process.

Using Bind Button

SAFE Select Enabled

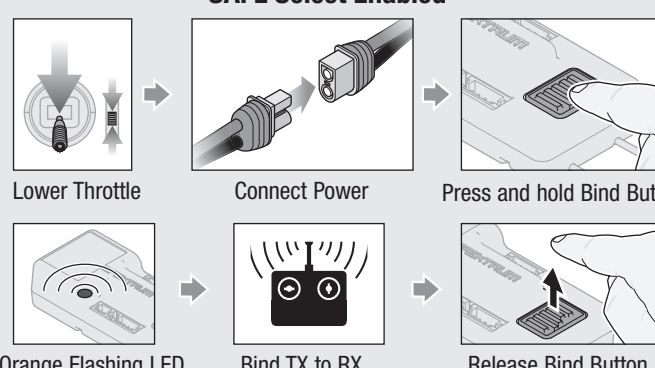

SAFE Select Enabled: The control surfaces cycle back and forth **twice** with a slight pause at neutral position every time the receiver is powered on.

SAFE Select Disabled

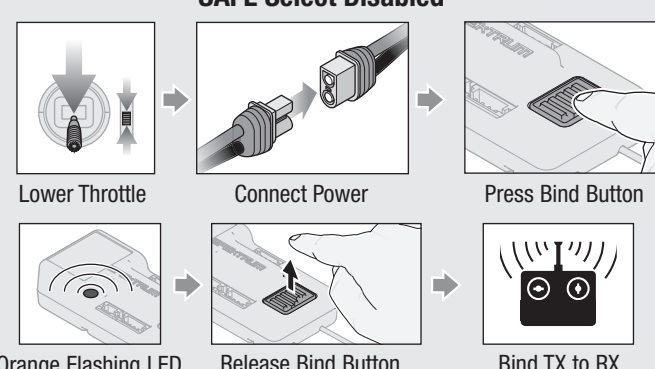

SAFE Select Disabled: The control surfaces cycle back and forth **once** every time the receiver is powered on.

Using Bind Plug

SAFE Select Enabled

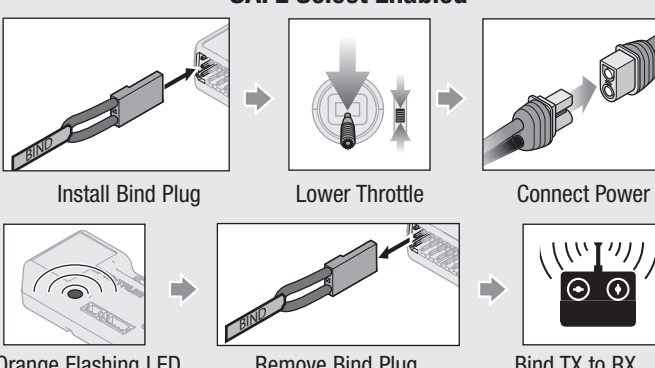

SAFE Select Enabled: The control surfaces cycle back and forth **twice** with a slight pause at neutral position every time the receiver is powered on.

SAFE Select Disabled

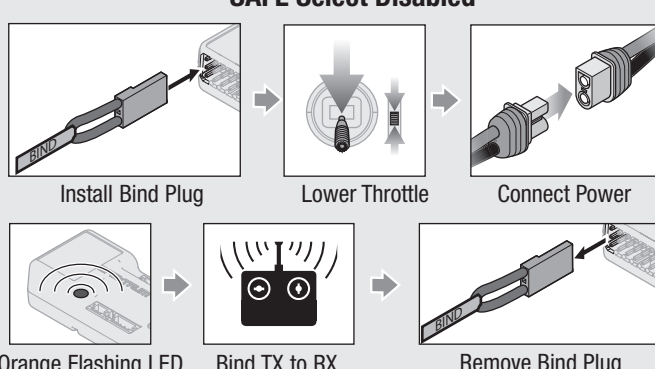

SAFE Select Disabled: The control surfaces cycle back and forth **once** every time the receiver is powered on.

SAFE Select Switch Designation

Once SAFE Select is enabled, you can choose to fly in SAFE mode full-time, or assign a switch. Any switch on any channel between 5 and 9 can be used on your transmitter.

If the aircraft is bound with SAFE Select disabled, the aircraft will be in AS3X mode exclusively.

CAUTION: Keep all body parts well clear of the propeller and keep the aircraft securely restrained in case of accidental throttle activation.

IMPORTANT: To be able to assign a switch, first verify:

- The aircraft was bound with SAFE Select enabled.
- Your choice for the SAFE Select switch is assigned to a channel between 5 and 9 (Gear, Aux1-4), and travel is set at 100% in each direction.
- The aileron, elevator, rudder and throttle direction are set to normal, not reverse.
- The aileron, elevator, rudder and throttle are set to 100% travel. If dual rates are in use, the switches need to be in the 100% position.

See your transmitter manual for more information about assigning a switch to a channel.

Assigning a Switch

1. Power on the transmitter.
2. Power on the aircraft.
3. Hold both transmitter sticks to the inside bottom corners, and toggle the desired switch 5 times quickly (1 toggle = full up and down).
4. The control surfaces of the aircraft will move, indicating the switch has been selected.

Repeat the process to assign a different switch or to deactivate the current switch.

SAFE Select Switch Assignment Stick Positions

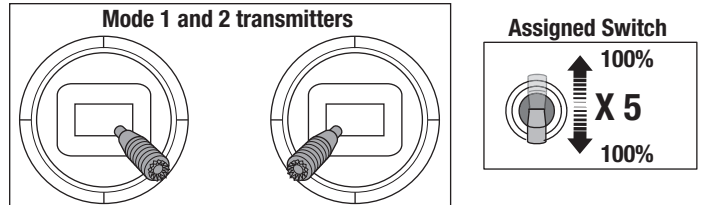

TIP: Use the channel monitor to verify channel movement.

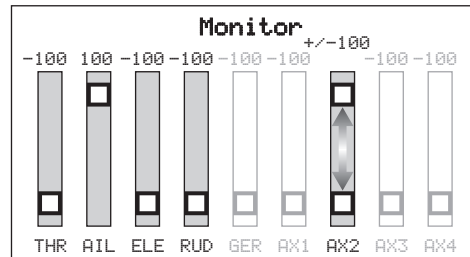

This example of the channel monitor shows the stick positions for assigning a switch, the switch selection on Aux2, and +/- 100% travel on the switch.

Dual Rates and Control Throws

Program your transmitter to set the rates and control throws based on your experience level. These values have been tested and are a good starting point to achieve successful first flight.

After flying, you may choose to adjust the values for the desired control response.

	Low Rate	High Rate
Aileron	14mm	20mm
Elevator	7mm	10mm
Rudder	22mm	22mm
Flap Travel	Half ▼ = 10mm Full ▼ = 20mm	

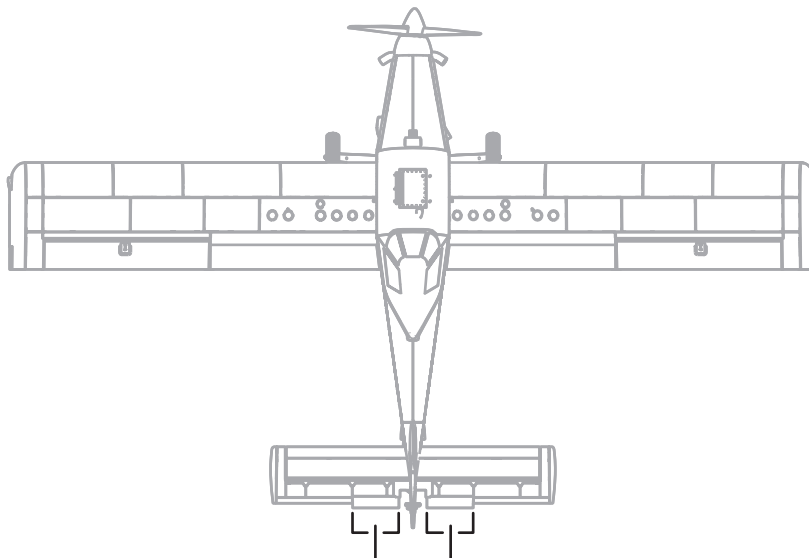

Measure the elevator travel on the elevator trim tabs

Control Surface Direction

Switch on the transmitter and connect the battery. Use the transmitter to operate the aileron, elevator, and rudder controls. View the aircraft from the rear when checking the control directions.

Ailerons

1. Move the aileron stick to the left. The right aileron should move down and the left aileron up, which will cause the aircraft to bank left.
2. Move the aileron stick to the right. The right aileron should move up and the left aileron down, which will cause the aircraft to bank right.

Elevators

3. Pull the elevator stick back. The elevators should move up, which will cause the aircraft to pitch up.
4. Push the elevator stick forward. The elevators should move down, which will cause the aircraft to pitch down.

Rudder

5. Move the rudder stick to the left. The rudder should move to the left, which will cause the aircraft to yaw left.
6. Move the rudder stick to the right. The rudder should move to the right, which will cause the aircraft to yaw right.

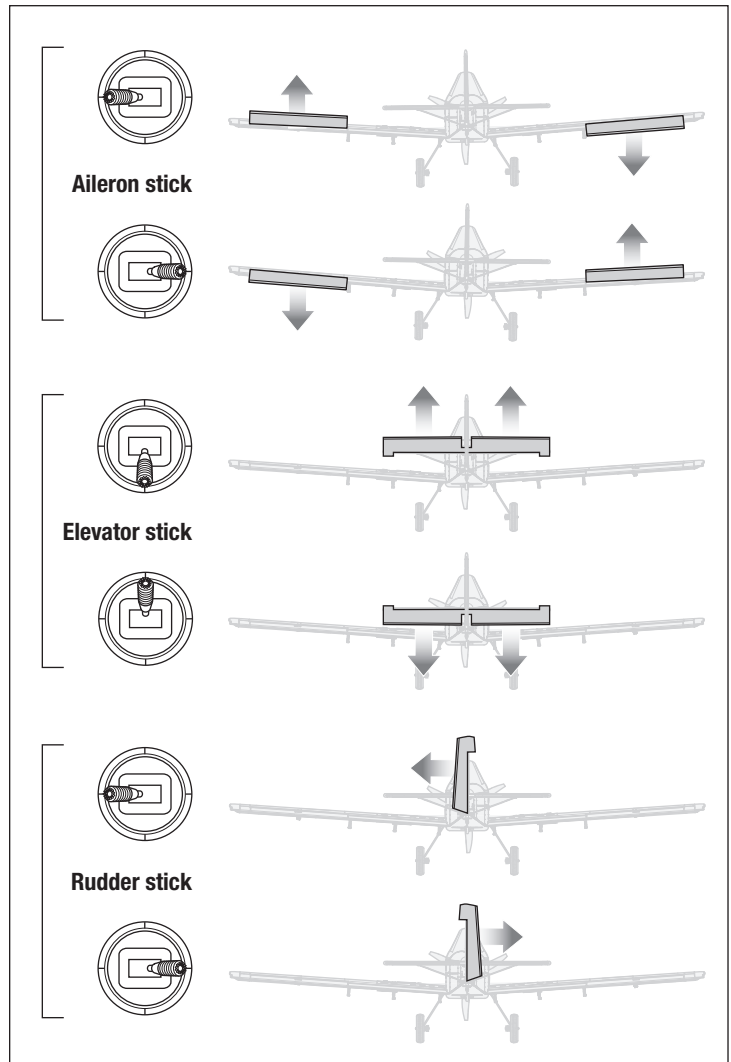

Control Horn and Servo Arm Settings

The table to the right shows the factory settings for the control horns and servo arms. Fly the aircraft at factory settings before making changes.

NOTICE: If control throws are changed from the factory settings, the AR637T gain values may need to be adjusted. Refer to the Spektrum AR637T manual for adjustment of gain values.

After flying, you may choose to adjust the linkage positions for the desired control response. See the table to the right.

Tuning	Horns	Arms
More control throw		
Less control throw		

Factory Setting	Horns	Arms
Elevator		
Rudder		
Aileron		
Flaps		

AS3X Control Direction Test (BNF)

This test ensures that the AS3X® control system is functioning properly. Assemble the aircraft and bind your transmitter to the receiver before performing this test.

1. Raise the throttle to any setting above 25%, then lower the throttle to activate AS3X technology. Activate throttle cut to prevent motor operation during this test.



CAUTION: Keep all body parts, hair and loose clothing away from the propeller, as these items could become entangled.

2. Move the entire aircraft as shown and ensure the control surfaces move in the direction indicated in the graphic. If the control surfaces do not respond as shown, do not fly the aircraft. Refer to the receiver manual for more information.

Once the AS3X system is active, control surfaces may move rapidly. This is normal. AS3X remains active until the battery is disconnected.

	Aircraft movement	AS3X Reaction
Elevator		
Aileron		
Rudder		

In Flight Trimming (BNF)

During your first flight, trim the aircraft for level flight at 1/2 throttle with flaps up. Make small trim adjustments with your transmitter's trim switches to straighten the aircraft's flight path.

After adjusting the trim, do not touch the control sticks for 3 seconds. This allows the receiver to learn the correct settings to optimize AS3X performance.

Failure to do so could affect flight performance.

3 Seconds

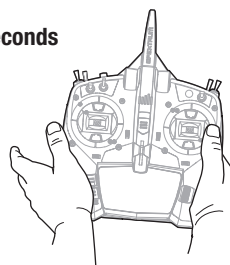

Flying Tips and Repairs

Consult local laws and ordinances before choosing a flying location.

Getting Started

Before you fly, range check the radio system. Refer to your specific transmitter instruction manual for range test information. When you first connect the battery to the airplane AS3X will not be active. After advancing the throttle the first time, the AS3X system will be active and it is normal to see the control surfaces react to aircraft movement. For your first flights set your transmitter timer or a stopwatch to 3.5 minutes. Adjust your timer for longer or shorter flights once you have flown the model.

Takeoff

Face the aircraft into the wind for takeoff. Set your transmitter to low rates and drop the flaps to the takeoff position if you desire. Flaps are not required, but lowering them makes takeoffs shorter.

Gradually increase the throttle to full, and steer on the ground with rudder as necessary to keep the aircraft rolling straight. Leave the elevator at neutral and allow the aircraft to accelerate up to speed on the ground, then pull up gently on the elevator to rotate for takeoff. When airborne, climb to a comfortable altitude, and return the flaps to the level position.

Flying

For your first flights, climb to a moderate altitude and get comfortable with the aircraft while the battery is fresh. Get a feel for the aircraft's low speed performance with the flaps up and down at a safe altitude (approximately 100 feet or more), before being required to make your first landing attempt. Land the aircraft when the timer expires. If at any time the motor power reduces, land the aircraft immediately to recharge the flight battery.

Landing

Plan to land the aircraft into the wind when possible. Fly downwind and turn into the wind to begin the approach. Lower the throttle and lower the flaps to the landing position (full down position.) Flaps will make the landing approach steeper and slower, and allow for a smoother landing. If there is a significant crosswind, only lower the flaps to the takeoff position (middle position) which will help maintain speed and better directional control during approach.

During the approach and descent, keep the wings level and the aircraft pointed into the wind. Keep the nose down and stay into the throttle to maintain speed and control during decent until the aircraft is ready to flare. As the airplane descends into ground effect, fully lower the throttle, pull the nose up more to bleed off airspeed (flare), and the aircraft will settle on its wheels.

If landing on grass, hold full up elevator after touchdown and when taxiing to prevent the aircraft from nosing over. Once on the ground, avoid sharp turns until the plane has slowed enough to prevent scraping the wingtips.

SAFE Select Flying Tips

When flying in SAFE Select mode the aircraft will return to level flight any time the aileron and elevator controls are at neutral. Applying aileron or elevator control will cause the airplane to bank, climb or dive. The amount the stick is moved will determine the attitude the airplane flies. Holding full control will push the aircraft to the pre-determined bank and roll limits, but it will not go past those angles.

When flying with SAFE Select, it is normal to hold the control stick deflected with moderate to full aileron input when flying through a turn. To fly smoothly with SAFE Select, avoid making frequent control changes and don't attempt to correct for minor deviations. Holding deliberate control inputs will command the aircraft to fly at a specific angle, and the model will make all corrections to maintain that flight attitude.

When flying with SAFE Select, throttle will make the aircraft climb or descend. Full throttle will cause the aircraft to pitch up and climb slightly. Mid throttle will keep the airplane flying level. Low throttle will cause the airplane to descend slightly nose-down.

Return the elevator and aileron controls to neutral before switching from SAFE Select mode to AS3X mode. If you do not neutralize controls when switching into AS3X mode, the control inputs used for SAFE Select mode will be excessive for AS3X mode and the aircraft will react immediately.

NOTICE: If a crash is imminent, reduce the throttle and trim fully. Failure to do so could result in extra damage to the airframe, as well as damage to the ESC and motor.

NOTICE: After any impact, always ensure the receiver is secure in the fuselage. If you replace the receiver, install the new receiver in the same orientation as the original receiver or damage may result.

NOTICE: Crash damage is not covered under warranty.

NOTICE: When you are finished flying, never leave the aircraft in direct sunlight or in a hot, enclosed area such as a car. Doing so can damage the aircraft.

Low Voltage Cutoff (LVC)

When a Li-Po battery is discharged below 3V per cell, it will not hold a charge. The ESC protects the flight battery from over-discharging using Low Voltage Cutoff (LVC). Before the battery charge decreases too much, LVC removes power supplied to the motor. Power to the motor reduces, showing that some battery power is reserved for flight control and safe landing.

Disconnect and remove the Li-Po battery from the aircraft after use to prevent trickle discharge. Charge your Li-Po battery to about half capacity before storage. During storage, make sure the battery charge does not fall below 3V per cell. LVC does not prevent the battery from over-discharge during storage.

NOTICE: Repeated flying to LVC will damage the battery.

Tip: Monitor your aircraft battery's voltage before and after flying by using a Li-Po Cell Voltage Checker (SPMXBC100, sold separately).

Oscillation

For most flight maneuvers the aircraft should fly smoothly and normal, but it is possible in some flight conditions you may see oscillation (the aircraft rocks back and forth on one axis due to overcontrol). If oscillation occurs, refer to the Troubleshooting Guide for more information.

Repairs

Thanks to the EPO foam material in this aircraft, repairs to the foam can be made using virtually any adhesive (hot glue, regular CA, epoxy, etc). When parts are not repairable, see the Replacement Parts List for ordering by item number. For a listing of all replacement and optional parts, refer to the list at the end of this manual.

NOTICE: Use of CA accelerant on your aircraft can damage paint. DO NOT handle the aircraft until accelerant fully dries.

Differences between SAFE Select and AS3X modes

This section is generally accurate but does not take into account flight speed, battery charge status, and other limiting factors.

		SAFE Select	AS3X
Control Input	Control stick is neutralized	Aircraft will self level	Aircraft will continue to fly at its present attitude
	Holding a small amount of control	Aircraft will bank or pitch to a moderate angle and maintain the attitude	Aircraft will continue to pitch or roll slowly
	Holding full control	Aircraft will bank or pitch to the predetermined limits and maintain the attitude	Aircraft will continue to roll or pitch rapidly
	Throttle	Full throttle: Climb Mid throttle: Level flight Low throttle: Decsend nose-down	Throttle will not affect flight response.

Post Flight

1. Disconnect the flight battery from the ESC (Required for Safety and battery life).
2. Power OFF the transmitter.
3. Remove the flight battery from the aircraft.
4. Recharge the flight battery.

5. Repair or replace all damaged parts.
6. Store the flight battery apart from the aircraft and monitor the battery charge.
7. Make note of the flight conditions and flight plan results, planning for future flights.

Motor Service

CAUTION: Always disconnect the flight battery before performing motor service.

Disassembly

1. Remove the 3mm screw holding the spinner to the prop shaft, remove the spinner.
2. Remove the nut securing the propeller, remove the propeller and prop adapter.
3. Remove the two self tapping screws holding the cowl onto the fuselage, remove the cowl.
4. Remove the four self tapping screws holding the motor plate to the motor mount.
5. Remove the four 3mm machine screws holding securing the motor to the motor plate.

Assembly

Assemble in reverse order.

- Correctly align and connect the motor wire colors with the ESC wires.
- Install the propeller with the numbers facing out from the motor.
- Tighten the prop nut and spinner screw to secure the propeller into place.

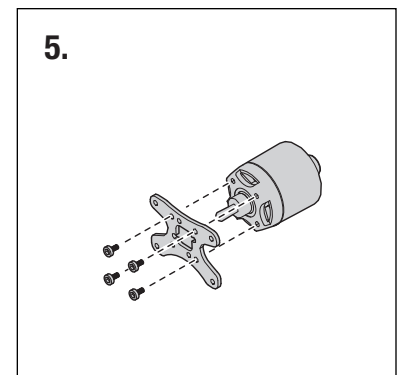
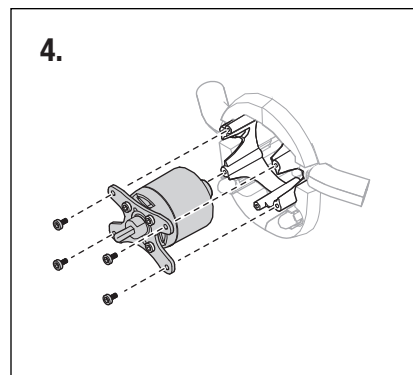
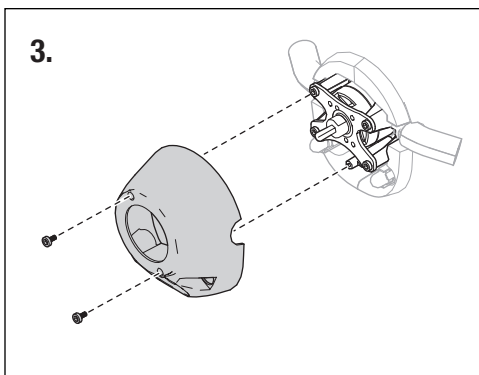
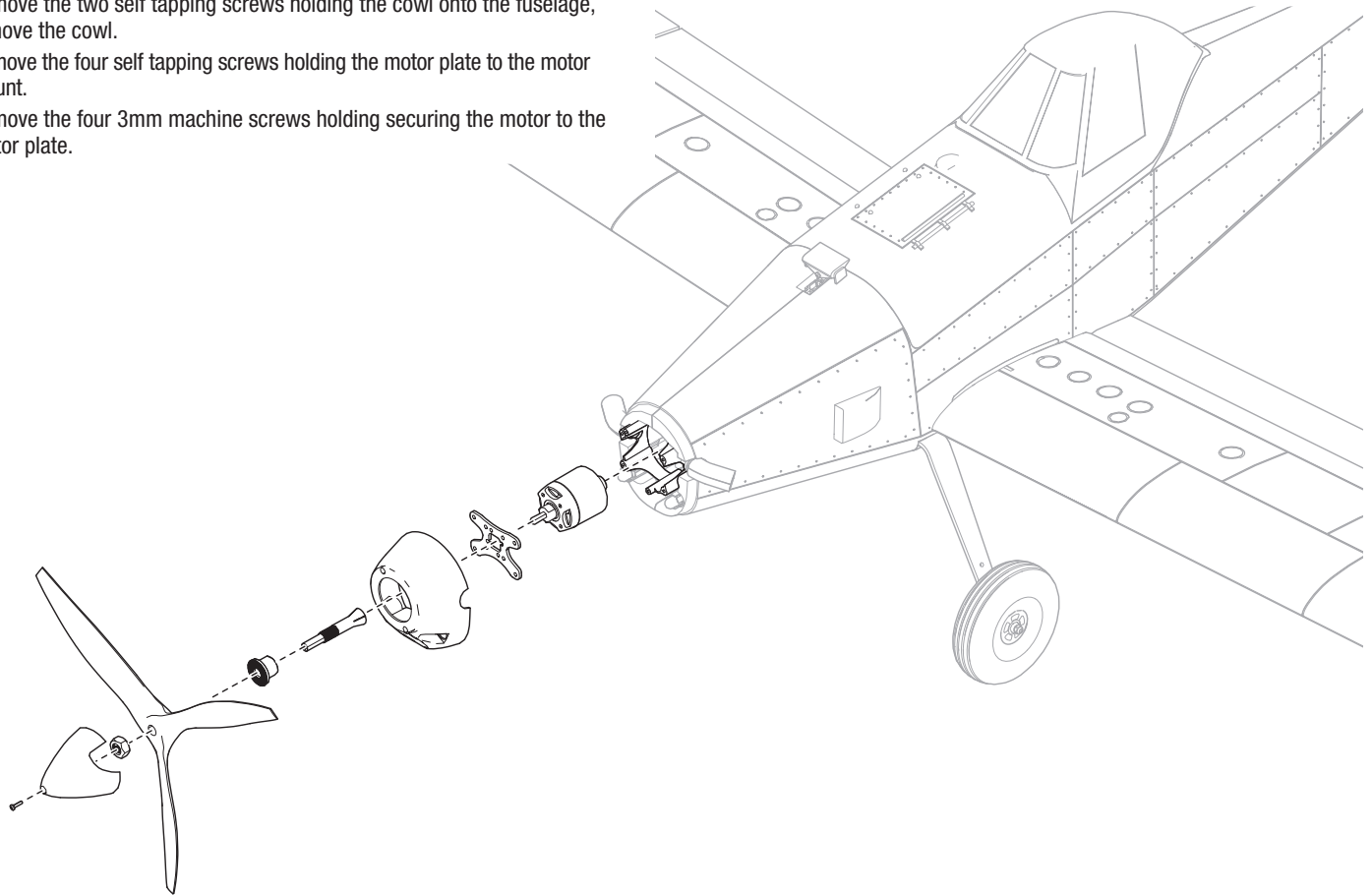

Troubleshooting Guide AS3X

Problem	Possible Cause	Solution
Oscillation	Damaged prop or nose cone	Replace prop or nose cone
	Imbalanced propeller	Balance the prop
	Motor vibration	Replace parts or correctly align prop or other parts and tighten fasteners as needed
	Loose receiver	Align and secure receiver in fuselage
	Loose aircraft controls	Tighten or otherwise secure parts (servo, arm, linkage, horn and control surface)
	Worn parts	Replace worn parts (especially prop, nose cone, or servo)
	Irregular servo movement	Replace servo and/or servo extension(s)
Inconsistent flight performance	Trim is not at neutral	If you adjust trim more than 8 clicks, adjust the pushrod to remove trim
	Sub-Trim is not at neutral	No Sub-Trim is allowed. Adjust the servo linkage
	Aircraft was not kept immobile for 5 seconds after battery connection	With the throttle stick in lowest position. Disconnect battery, then reconnect battery and keep the aircraft still for 5 seconds
Incorrect response to the AS3X Control Direction Test	Incorrect direction settings in the receiver, which can cause a crash	DO NOT fly. Correct the direction settings (refer to the receiver manual), then fly

Troubleshooting Guide

Problem	Possible Cause	Solution
Aircraft will not respond to throttle but responds to other controls	Throttle not at idle and/or throttle trim too high	Reset controls with throttle stick and throttle trim at lowest setting
	Throttle servo travel is lower than 100%	Make sure throttle servo travel is 100% or greater
	Throttle channel is reversed	(With battery disconnected from aircraft) Reverse throttle channel on transmitter
	Motor disconnected from ESC	Make sure motor is connected to the ESC
Excessive propeller noise or Excessive vibration	Damaged propeller, nose cone, collet or motor	Replace damaged parts
	Propeller is out of balance	Balance or replace propeller
	Propeller nut is too loose	Tighten the propeller nut
Reduced flight time or aircraft underpowered	Flight battery charge is low	Completely recharge flight battery
	Flight battery damaged	Replace flight battery and follow flight battery instructions
	Flight conditions may be too cold	Make sure battery is not cold before use (Do not apply heat to the battery)
	Battery capacity too low for flight conditions	Replace battery or use a larger capacity battery
Aircraft will not Bind (during binding) to transmitter	Transmitter too near aircraft during binding process	Move powered transmitter a few feet from aircraft, disconnect and reconnect flight battery to aircraft
	Aircraft or transmitter is too close to large metal object, wireless source or another transmitter	Move aircraft and transmitter to another location and attempt binding again
	The bind plug is not installed correctly in the bind port	Install bind plug in bind port and bind the aircraft to the transmitter
	Flight battery/transmitter battery charge is too low	Replace/recharge batteries
	Bind switch or button not held long enough during bind process	Power off transmitter and repeat bind process. Hold transmitter bind button or switch until receiver is bound
Aircraft will not connect (after binding) to transmitter	Transmitter too near aircraft during connecting process	Move powered transmitter a few feet from aircraft, disconnect and reconnect flight battery to aircraft
	Aircraft or transmitter is too close to large metal object, wireless source or another transmitter	Move aircraft and transmitter to another location and attempt connecting again
	Bind plug left installed in bind port	Rebind transmitter to the aircraft and remove the bind plug before cycling power
	Aircraft bound to different model memory (ModelMatch™ radios only)	Select correct model memory on transmitter
	Flight battery/Transmitter battery charge is too low	Replace/recharge batteries
	Transmitter may have been bound to a different aircraft using different DSM protocol	Bind aircraft to transmitter
Control surface does not move	Control surface, control horn, linkage or servo damage	Replace or repair damaged parts and adjust controls
	Wire damaged or connections loose	Do a check of wires and connections, connect or replace as needed
	Transmitter is not bound correctly or the incorrect airplanes was selected	Re-bind or select correct airplanes in transmitter
	Flight battery charge is low	Fully recharge flight battery
	BEC (Battery Elimination Circuit) of the ESC is damaged	Replace ESC
Controls reversed	Transmitter settings are reversed	Perform the Control Direction Test and adjust the controls on transmitter appropriately
Motor power pulses then motor loses power	ESC uses default soft Low Voltage Cutoff (LVC)	Recharge flight battery or replace battery that is no longer performing
	Weather conditions might be too cold	Postpone flight until weather is warmer
	Battery is old, worn out, or damaged	Replace battery
	Battery C rating might be too small	Use recommended battery

Float Installation (Optional)

Float Assembly

1. Install the 2 cross members (A) to the left and right floats as shown.
2. Install the front and rear float struts to the floats and secure the assembly together using the included 4 float plates (B) and 3mm x 25mm machine screws (C). The front strut has slightly more of an angle than the rear strut (Figure 1).
3. Install the front support members (D) as shown using the included self tapping screws (E).

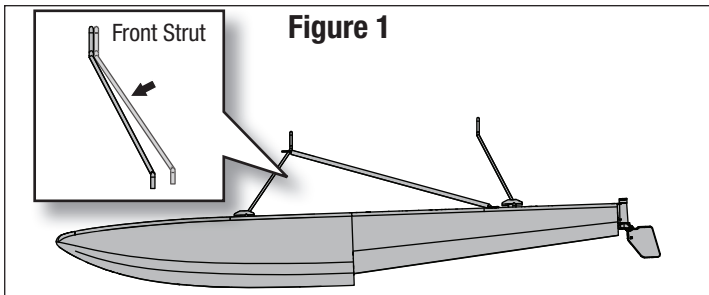

Float Assembly Installation

1. Align and mount the float set assembly to the bottom of the fuselage.
2. Secure the back section of the floats to the fuselage using the included bracket (F) and two 3mm x 10mm self tapping screws (G).
3. Secure the front section of the floats using the two included 3mm x 12mm self tapping screws (H) to secure the front support members to the bottom of the fuselage.
4. Attach the included wire from each float rudder (I) to the pull-pull horn (J) using the two included pins (K).

Disassemble in reverse order.

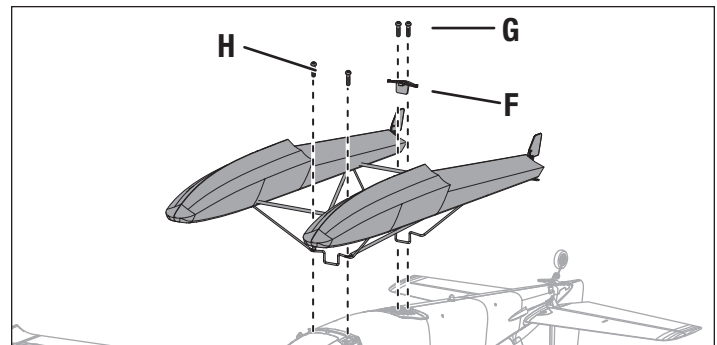
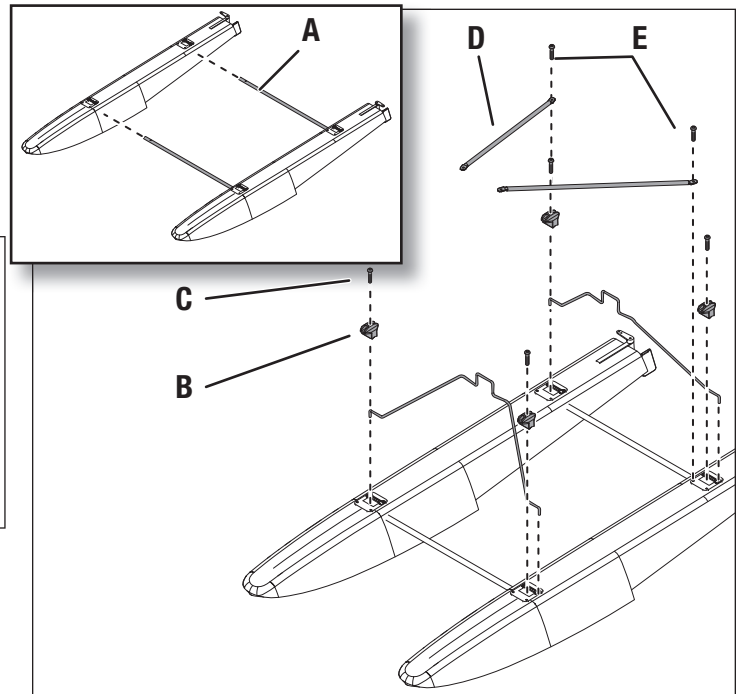
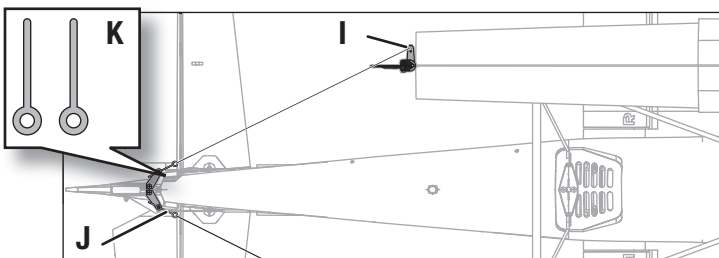

Flying Off Water

Flying off water poses a higher risk because piloting errors or water conditions can cause the aircraft to become stranded. Only fly from the water when a level of comfort has been achieved flying the aircraft from the ground.

Pre-Flight

Ensure the optional floats are secure on the fuselage and the water rudders are correctly connected and operating with the main rudder before putting the aircraft in the water. Select an area to fly that does not have water currents, salt water, or debris. Look around the flight area and be aware of trees, docks, buoys, or other obstacles. Always fly with a spotter and avoid swimmers, boaters, people fishing, and people on the beach.

Taxiing

When taxiing, use low throttle settings and the rudders to steer. Hold up elevator to help keep the rudders in the water and the nose of the floats above the surface. Steer into the wind when turning, and crab into the wind if crosswind taxiing is required. When turning or crabbing into the wind, apply aileron against the wind to keep the upwind side of the wing down and prevent the aircraft from being flipped over. Do not apply down elevator when the airplane is taxiing or during the takeoff run.

On Step

When speed increases with throttle, the floats will rise out of the water and begin to plane on the surface of the water, riding "on step." The floats will come on step at a speed below flight speed, this is a transitional phase when the aircraft is not up to flight speed yet. This is considered a high speed taxi. Do not attempt to take off as soon as the aircraft comes on step. Use low to medium throttle and hold up elevator to manage speed on the water during a high speed taxi.

Takeoff

To lift off from the water, set the flaps to the takeoff position, hold up elevator and accelerate the aircraft to bring it on step. Relax the up elevator as the airplane comes on step and accelerate to flight speed with full throttle. When the aircraft is travelling at a sufficient speed, pull back slightly on the elevator to rotate for liftoff.

Landing

To land on the water, set the flaps to the landing position, and fly into the wind. Reduce the throttle to a low setting but keep some power during the approach. As the aircraft settles into ground effect, reduce the throttle fully and hold up elevator to flare. Hold up elevator through the touch down and as the airplane decelerates on the water.

WARNING: Never attempt to retrieve a downed aircraft by swimming unless you are sufficiently trained and/or there is another person available to respond in the case of an emergency.

CAUTION: Have a plan for retrieval in the event the airplane becomes stranded. Never retrieve a downed model in the water alone.

CAUTION: If at any time water splashes in the fuselage while flying from water, bring the airplane to shore, open the battery hatch and immediately remove any water that may have gotten in the fuselage. Leave the battery hatch open overnight to let the inside dry out and to prevent moisture damage to the electronic components. Failure to do so could cause the electronic components to fail, which could result in a crash.

TIP: Use a fishing pole with heavy line as a retrieval tool. Attach a tennis ball to the line, and throw the ball past a stranded aircraft to retrieve it.

Ski Installation (Optional)

Ski Installation

1. Remove the wheels and axles from the landing gear.
 2. Place the springs on the axle retainers and thread the axles included with the skis into the axle retainers.
 3. Mount the skis onto the axles and secure them in place with the 3mm nut.
 4. Mount the brackets for the limit cords to the landing gear with the included 3x8mm screw.
 5. Remove the tail wheel and install the tail ski as shown.
 6. Loosen one of the mounting screws for the tail wheel bracket and tie the limit cord for the tail ski from the nose of the ski to the screw.
 7. Tighten the bracket screw.
- Disassemble in reverse order.

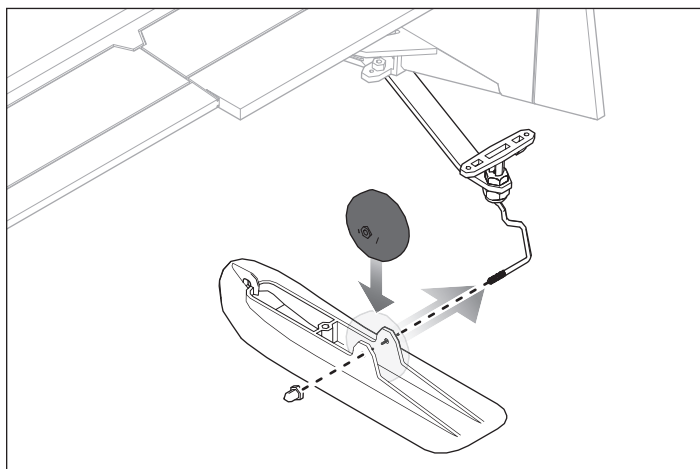
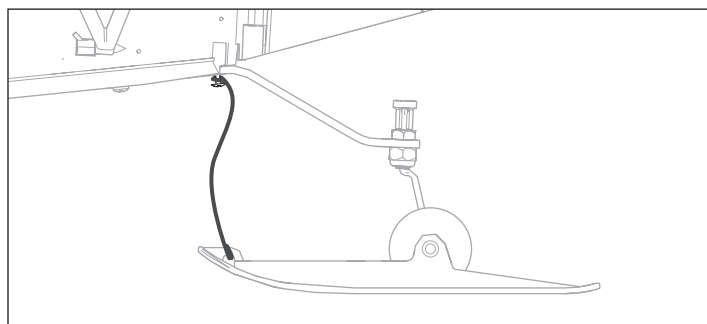
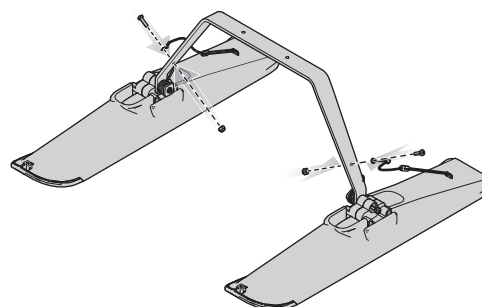
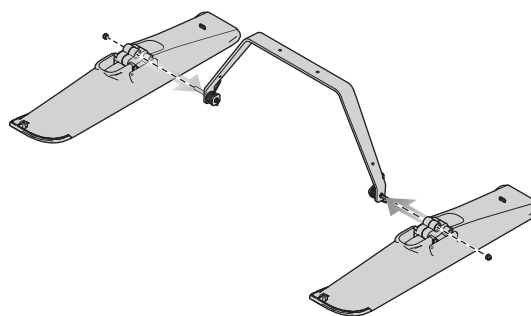
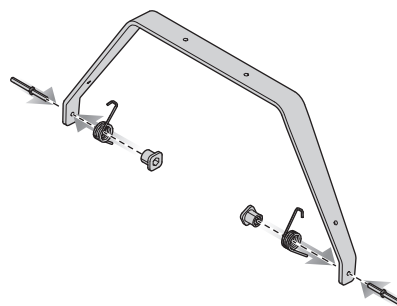
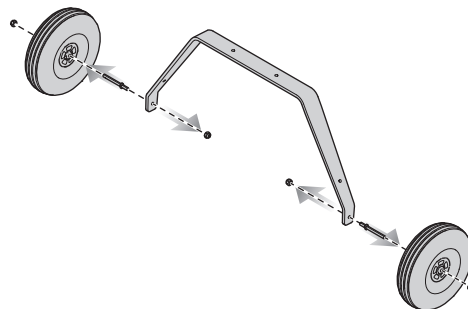

Replacement Parts

Part #	Description
EFL16451	Fuselage Set: Air Tractor
EFL16452	Wing Set: Air Tractor
EFL16453	Battery Hatch: Air Tractor
EFL16454	Canopy: Air Tractor
EFL16455	Cowl: Air Tractor
EFL16456	Hardware Set: Air Tractor
EFL16457	Landing Gear Set: Air Tractor
EFL16458	Wheel Set: Air Tractor
EFL16459	Horizontal Stab Struts: Air Tractor
EFL16460	Pilot: Air Tractor
EFL16461	Pushrod Set : Air Tractor
EFL16462	Spinner : Air Tractor
EFL16463	Motor Mount: Air Tractor
EFL16464	Plastic Parts Set: Air Tractor
EFL16465	Decal Sheet: Air Tractor
EFL16466	Wing Tube set: Air Tractor
EFL16467	Hatch Latch assembly: Air Tractor
EFL5263	Prop Adapter: Timber/ Tractor
EFL5962	3 Blade Propeller: 11 x 7.5
EFLA1050	50AMP Brushless ESC
EFLM17552	BL10 Motor 800KV: Turbo Timber/Air Tractor
SPMSA330R	Servo: 9 Gram Reversed
SPMSA332	Servo: 9 Gram MG

Optional Parts

Part #	Description
EFL16469	Ski Set: Air Tractor
EFL5261	E-flite Float Set: Timber
SPMXAE1060	ESC: 60AMP Avian Brushless SMART
EFLA250	Park Flyer Tool Assortment, 5 pc
SPMXBC100	SMART Battery Checker and Servo Driver
EFLA111	Li-Po Cell Voltage Checker
DYN1405	Li-Po Charge Protection Bag, Large
DYN1400	Li-Po Charge Protection Bag, Small
SPMR1000	DXe Transmitter Only
SPMR6655	DX6e Transmitter Only
SPMR6750	DX6 Transmitter Only MD2
SPMR8000	DX8 Transmitter Only MD2
SPMR8100	DX8e 8CH Transmitter Only
SPMR9910	DX9 Black Transmitter Only
SPMR12000	iX12 12 Channel Transmitter Only
SPMR20100	iX20 20 Channel Transmitter Only
SPMX22003S30	11.1V 2200mAh 3S 30C Smart LiPo, IC3
SPMX22003S50	11.1V 2200mAh 3S 50C Smart LiPo, IC3
SPMX22003S100	11.1V 2200mAh 3S 100C Smart LiPo, IC3
SPMX32003S30	11.1V 3200mAh 3S 30C Smart LiPo, IC3
SPMX22004S30	14.8V 2200mAh 4S 30C Smart LiPo, IC3
SPMX22004S50	14.8V 2200mAh 4S 50C Smart LiPo, IC3
SPMX22004S100	14.8V 2200mAh 4S 100C Smart LiPo, IC3
SPMX32004S50	14.8V 3200mAh 4S 50C Smart LiPo, IC3
SPMX32004S100	14.8V 3200mAh 4S 100C Smart LiPo, IC3
SPMXC1020	Smart S120 USB-C Charger, 1x20W
SPMXC1000	Smart S1200 DC Charger, 1x200W
SPMXC1010	Smart S2100 AC Charger, 2x100W
Telemetry Sensors	
SPMA9574	Aircraft Telemetry Airspeed Indicator
SPMA9589	Aircraft Telemetry Altitude and Variometer Sensor
SPMA9587	Aircraft Telemetry GPS Sensor

Recommended Receivers (PNP)

Part Number	Description
SPMAR620	AR620 6-Channel Sport Air Receiver
Telemetry Equipped Receivers	
SPMAR6600T	AR6600T 6-Channel Air Integrated Telemetry Receiver
SPMAR6270T	AR6270T 6-Channel Carbon Fuse Integrated Telemetry Receiver
SPMAR8010T	AR8010T 8-Channel Air Integrated Telemetry Receiver
SPMAR9030T	AR9030T 9-Channel Air Integrated Telemetry Receiver
AS3X Equipped Receivers	
SPMAR637T	AR637T 6-Channel AS3X Sport Receiver

AMA National Model Aircraft Safety Code

Effective January 1, 2014

A. GENERAL

A model aircraft is a non-human-carrying aircraft capable of sustained flight in the atmosphere. It may not exceed limitations of this code and is intended exclusively for sport, recreation, education and/or competition. All model flights must be conducted in accordance with this safety code and any additional rules specific to the flying site.

1. Model aircraft will not be flown:
 - (a) In a careless or reckless manner.
 - (b) At a location where model aircraft activities are prohibited.
2. Model aircraft pilots will:
 - (a) Yield the right of way to all man carrying aircraft.
 - (b) See and avoid all aircraft and a spotter must be used when appropriate. (AMA Document #540-D.)
 - (c) Not fly higher than approximately 400 feet above ground level within three (3) miles of an airport, without notifying the airport operator.
 - (d) Not interfere with operations and traffic patterns at any airport, heliport or seaplane base except where there is a mixed use agreement.
 - (e) Not exceed a takeoff weight, including fuel, of 55 pounds unless in compliance with the AMA Large Model Aircraft program. (AMA Document 520-A.)
 - (f) Ensure the aircraft is identified with the name and address or AMA number of the owner on the inside or affixed to the outside of the model aircraft. (This does not apply to model aircraft flown indoors).
 - (g) Not operate aircraft with metal-blade propellers or with gaseous boosts except for helicopters operated under the provisions of AMA Document #555.
 - (h) Not operate model aircraft while under the influence of alcohol or while using any drug which could adversely affect the pilot's ability to safely control the model.
 - (i) Not operate model aircraft carrying pyrotechnic devices which explode or burn, or any device which propels a projectile or drops any object that creates a hazard to persons or property.

Exceptions:

 - Free Flight fuses or devices that burn producing smoke and are securely attached to the model aircraft during flight.
 - Rocket motors (using solid propellant) up to a G-series size may be used provided they remain attached to the model during flight. Model rockets may be flown in accordance with the National Model Rocketry Safety Code but may not be launched from model aircraft.
 - Officially designated AMA Air Show Teams (AST) are authorized to use devices and practices as defined within the Team AMA Program Document (AMA Document #718).
 - (j) Not operate a turbine-powered aircraft, unless in compliance with the AMA turbine regulations. (AMA Document #510-A).
3. Model aircraft will not be flown in AMA sanctioned events, air shows or model demonstrations unless:
 - (a) The aircraft, control system and pilot skills have successfully demonstrated all maneuvers intended or anticipated prior to the specific event.
 - (b) An inexperienced pilot is assisted by an experienced pilot.
4. When and where required by rule, helmets must be properly worn and fastened. They must be OSHA, DOT, ANSI, SNELL or NOCSAE approved or comply with comparable standards.

B. RADIO CONTROL

1. All pilots shall avoid flying directly over unprotected people, vessels, vehicles or structures and shall avoid endangerment of life and property of others.
2. A successful radio equipment ground-range check in accordance with manufacturer's recommendations will be completed before the first flight of a new or repaired model aircraft.
3. At all flying sites a safety line(s) must be established in front of which all flying takes place (AMA Document #706.)
 - (a) Only personnel associated with flying the model aircraft are allowed at or in front of the safety line.
 - (b) At air shows or demonstrations, a straight safety line must be established.
 - (c) An area away from the safety line must be maintained for spectators.
 - (d) Intentional flying behind the safety line is prohibited.
4. RC model aircraft must use the radio-control frequencies currently allowed by the Federal Communications Commission (FCC). Only individuals properly licensed by the FCC are authorized to operate equipment on Amateur Band frequencies.
5. RC model aircraft will not operate within three (3) miles of any pre-existing flying site without a frequency-management agreement (AMA Documents #922 and #923.)
6. With the exception of events flown under official AMA Competition Regulations, excluding takeoff and landing, no powered model may be flown outdoors closer than 25 feet to any individual, except for the pilot and the pilot's helper(s) located at the flight line.
7. Under no circumstances may a pilot or other person touch a model aircraft in flight while it is still under power, except to divert it from striking an individual.
8. RC night flying requires a lighting system providing the pilot with a clear view of the model's attitude and orientation at all times. Hand-held illumination systems are inadequate for night flying operations.
9. The pilot of a RC model aircraft shall:
 - (a) Maintain control during the entire flight, maintaining visual contact without enhancement other than by corrective lenses prescribed for the pilot.
 - (b) Fly using the assistance of a camera or First-Person View (FPV) only in accordance with the procedures outlined in AMA Document #550.
 - (c) Fly using the assistance of autopilot or stabilization system only in accordance with the procedures outlined in AMA Document #560.

Please see your local or regional modeling association's guidelines for proper, safe operation of your model aircraft.

Limited Warranty

What this Warranty Covers

Horizon Hobby, LLC, (Horizon) warrants to the original purchaser that the product purchased (the "Product") will be free from defects in materials and workmanship at the date of purchase.

What is Not Covered

This warranty is not transferable and does not cover (i) cosmetic damage, (ii) damage due to acts of God, accident, misuse, abuse, negligence, commercial use, or due to improper use, installation, operation or maintenance, (iii) modification of or to any part of the Product, (iv) attempted service by anyone other than a Horizon Hobby authorized service center, (v) Product not purchased from an authorized Horizon dealer, or (vi) Product not compliant with applicable technical regulations, or (vii) use that violates any applicable laws, rules, or regulations.

OTHER THAN THE EXPRESS WARRANTY ABOVE, HORIZON MAKES NO OTHER WARRANTY OR REPRESENTATION, AND HEREBY DISCLAIMS ANY AND ALL IMPLIED WARRANTIES, INCLUDING, WITHOUT LIMITATION, THE IMPLIED WARRANTIES OF NON-INFRINGEMENT, MERCHANTABILITY AND FITNESS FOR A PARTICULAR PURPOSE. THE PURCHASER ACKNOWLEDGES THAT THEY ALONE HAVE DETERMINED THAT THE PRODUCT WILL SUITABLY MEET THE REQUIREMENTS OF THE PURCHASER'S INTENDED USE.

Purchaser's Remedy

Horizon's sole obligation and purchaser's sole and exclusive remedy shall be that Horizon will, at its option, either (i) service, or (ii) replace, any Product determined by Horizon to be defective. Horizon reserves the right to inspect any and all Product(s) involved in a warranty claim. Service or replacement decisions are at the sole discretion of Horizon. Proof of purchase is required for all warranty claims. SERVICE OR REPLACEMENT AS PROVIDED UNDER THIS WARRANTY IS THE PURCHASER'S SOLE AND EXCLUSIVE REMEDY.

Limitation of Liability

HORIZON SHALL NOT BE LIABLE FOR SPECIAL, INDIRECT, INCIDENTAL OR CONSEQUENTIAL DAMAGES, LOSS OF PROFITS OR PRODUCTION OR COMMERCIAL LOSS IN ANY WAY, REGARDLESS OF WHETHER SUCH CLAIM IS BASED IN CONTRACT, WARRANTY, TORT, NEGLIGENCE, STRICT LIABILITY OR ANY OTHER THEORY OF LIABILITY, EVEN IF HORIZON HAS BEEN ADVISED OF THE POSSIBILITY OF SUCH DAMAGES. Further, in no event shall the liability of Horizon exceed the individual price of the Product on which liability is asserted. As Horizon has no control over use, setup, final assembly, modification or misuse, no liability shall be assumed nor accepted for any resulting damage or injury. By the act of use, setup or assembly, the user accepts all resulting liability. If you as the purchaser or user are not prepared to accept the liability associated with the use of the Product, purchaser is advised to return the Product immediately in new and unused condition to the place of purchase.

Law

These terms are governed by Illinois law (without regard to conflict of law principals). This warranty gives you specific legal rights, and you may also have other rights which vary from state to state. Horizon reserves the right to change or modify this warranty at any time without notice.

WARRANTY SERVICES

Questions, Assistance, and Services

Your local hobby store and/or place of purchase cannot provide warranty support or service. Once assembly, setup or use of the Product has been started, you must contact your local distributor or Horizon directly. This will enable Horizon to better answer your questions and service you in the event that you may need any assistance. For questions or assistance, please visit our website at www.horizonhobby.com, submit a Product Support Inquiry, or call the toll free telephone number referenced in the Warranty and Service Contact Information section to speak with a Product Support representative.

Inspection or Services

If this Product needs to be inspected or serviced and is compliant in the country you live and use the Product in, please use the Horizon Online Service Request submission process found on our website or call Horizon to obtain a Return Merchandise Authorization (RMA) number. Pack the Product securely using a shipping carton. Please note that original boxes may be included, but are not designed to withstand the rigors of shipping without additional protection. Ship via a carrier that provides tracking and insurance for lost or damaged parcels, as Horizon is not responsible for merchandise until it arrives and is accepted at our facility. An Online Service Request is available at <https://www.horizonhobby.com/content/service-center-render-service-center>. If you do not have internet access, please contact Horizon Product Support to obtain a RMA number along with instructions for submitting your product for service. When calling Horizon, you will be asked to provide your complete name, street address, email address and phone number where you can be reached during business hours. When sending product into Horizon, please include your RMA number, a list of the included items, and a brief summary of the problem. A copy of your original sales receipt must be included for warranty consideration. Be sure your name, address, and RMA number are clearly written on the outside of the shipping carton.

NOTICE: Do not ship LiPo batteries to Horizon. If you have any issue with a LiPo battery, please contact the appropriate Horizon Product Support office.

Warranty Requirements

For Warranty consideration, you must include your original sales receipt verifying the proof-of-purchase date. Provided warranty conditions have been met, your Product will be serviced or replaced free of charge. Service or replacement decisions are at the sole discretion of Horizon.

Non-Warranty Service

Should your service not be covered by warranty, service will be completed and payment will be required without notification or estimate of the expense unless the expense exceeds 50% of the retail purchase cost.

By submitting the item for service you are agreeing to payment of the service without notification. Service estimates are available upon request. You must include this request with your item submitted for service. Non-warranty 10/15 service estimates will be billed a minimum of ½ hour of labor. In addition you will be billed for return freight. Horizon accepts money orders and cashier's checks, as well as Visa, MasterCard, American Express, and Discover cards. By submitting any item to Horizon for service, you are agreeing to Horizon's Terms and Conditions found on our website http://www.horizonhobby.com/content/_service-center_render-service-center.

ATTENTION: Horizon service is limited to Product compliant in the country of use and ownership. If received, a non-compliant Product will not be serviced. Further, the sender will be responsible for arranging return shipment of the un-serviced Product, through a carrier of the sender's choice and at the sender's expense. Horizon will hold non-compliant Product for a period of 60 days from notification, after which it will be discarded.

10/15

Contact Information

Country of Purchase	Horizon Hobby	Contact Information	Address
United States of America	Horizon Service Center (Repairs and Repair Requests)	servicecenter.horizonhobby.com/RequestForm/	2904 Research Rd Champaign, Illinois, 61822 USA
	Horizon Product Support (Product Technical Assistance)	productsupport@horizonhobby.com 877-504-0233	
	Sales	websales@horizonhobby.com 800-338-4639	
European Union	Horizon Technischer Service	service@horizonhobby.eu	Hanskampring 9 D 22885 Barsbüttel, Germany
	Sales: Horizon Hobby GmbH	+49 (0) 4121 2655 100	

FCC Information

FCC ID: BRWTIARLGTNG1

This device complies with part 15 of the FCC rules. Operation is subject to the following two conditions: (1) This device may not cause harmful interference, and (2) this device must accept any interference received, including interference that may cause undesired operation.

 **CAUTION:** Changes or modifications not expressly approved by the party responsible for compliance could void the user's authority to operate the equipment.

This product contains a radio transmitter with wireless technology which has been tested and found to be compliant with the applicable regulations governing a radio transmitter in the 2.400GHz to 2.4835GHz frequency range.

Supplier's Declaration of Conformity

Air Tractor 1.5m BNF Basic with AS3X and SAFE Select
EFL16450/EFL16475

 This device complies with part 15 of the FCC Rules. Operation is subject to the following two conditions: (1) This device may not cause harmful interference, and (2) this device must accept any interference received, including interference that may cause undesired operation.

 **CAUTION:** Changes or modifications not expressly approved by the party responsible for compliance could void the user's authority to operate the equipment.

NOTE: This equipment has been tested and found to comply with the limits for a Class B digital device, pursuant to part 15 of the FCC Rules. These limits are designed to provide reasonable protection against harmful interference in a residential installation. This equipment generates, uses and can radiate radio frequency energy and, if not installed and used in accordance with the instructions, may cause harmful interference to radio communications. However, there is no guarantee that interference will not occur in a particular installation. If this equipment does cause harmful interference to radio or television reception, which can be determined by turning the equipment off and on, the user is encouraged to try to correct the interference by one or more of the following measures:

- Reorient or relocate the receiving antenna.
- Increase the separation between the equipment and receiver.
- Connect the equipment into an outlet on a circuit different from that to which the receiver is connected.
- Consult the dealer or an experienced radio/TV technician for help.

Horizon Hobby, LLC
2904 Research Rd.,
Champaign, IL 61822
Email: compliance@horizonhobby.com
Web: HorizonHobby.com

IC Information

CAN ICES-3 (B)/NMB-3(B) IC: 6157A-TIARLGTNG1

This device complies with Industry Canada licence-exempt RSS standard(s). Operation is subject to the following two conditions: (1) this device may not cause interference, and (2) this device must accept any interference, including interference that may cause undesired operation of the device.

Compliance Information for the European Union

EU Compliance Statement:



EFL16450 Air Tractor 1.5m BNF BASIC; Horizon Hobby, LLC hereby declares that this product is in compliance with the essential requirements and other relevant provisions of the RED and EMC Directives.

EFL16475 Air Tractor 1.5m PNP; Horizon Hobby, LLC hereby declares that this product is in compliance with the essential requirements and other relevant provisions of the EMC Directive.

A copy of the EU Declaration of Conformity is available online at:
<http://www.horizonhobby.com/content/support-render-compliance>.

Operating Frequency
Band: 2404 – 2476 MHz
Max EIRP: 3dBm



Instructions for disposal of WEEE by users in the European Union



This product must not be disposed of with other waste. Instead, it is the user's responsibility to dispose of their waste equipment by handing it over to a designated collections point for the recycling of waste electrical and electronic equipment. The separate collection and recycling of your waste equipment at the time of disposal will help to conserve natural resources and make sure that it is recycled in a manner that protects human health and the environment. For more information about where you can drop off your waste equipment for recycling, please contact your local city office, your household waste disposal service or where you purchased the product.



© 2020 Horizon Hobby, LLC.

E-flite, AS3X, DSM, DSM2, DSMX, Spektrum Airware, Bind-N-Fly, BNF, the Bind-N-Fly logo, Plug-N-Play, SAFE, the SAFE logo, ModelMatch, and the Horizon Hobby logo are trademarks or registered trademarks of Horizon Hobby, LLC.

The Spektrum trademark is used with permission of Bachmann Industries, Inc.

All other trademarks, service marks and logos are property of their respective owners.

US 9,056,667. US 8,672,726. US 9,753,457. US 10,078,329. US 9,930,567. US 10,419,970.

<https://www.horizonhobby.com/content/e-flite-rc>